

TABLE OF CONTENTS

PROGRAMMING OUTLINE	2	PROGRAMMING OVERVIEW	10
SYSTEM POWER-UP	3	Program Functions	10
First Time Power-up	3	Program Selectors	10
Restoring Factory Defaults	3	Program Values	10
Internal Diagnostic Checks	3	Default Values	10
Watchdog Monitor	3	Notation for Functions, Selectors & Values	10
CONTROL STATION OVERVIEW	4	FACTORY DEFAULTS & UL PROGRAMMING REQUIREMENTS	11
Power-up Indications	4	PROGRAMMING THE CP-90	12
Keypad Lighting	4	Entering Program Level	12
Keypad Supervision	4	Exiting Programming Level	12
Keypad Lockout Timer	4	Programming Level Timer	12
Programming Level Timer	4	Control Station Keys During Programming	12
Control Station Operation	4	Programming Cycle	13
SYSTEM ZONES	5	Function Field	13
Exterior	5	Selector Field	13
Interior	5	Value Field	13
Restricted Interior	5	Changing Values	14
Fire	5	CP-90 MEMORY LAYOUT	15
Emergency	5	About Sensor Numbers	15
Police/Hold-up	5	About Control Station Numbers	15
Arm/Disarm Toggle	5	SENSOR SETUP	16
Delayed Remote Emergency	5	SX Format	16
Delayed Remote Police/Hold-up	5	MegaCode Format	16
Guard Zone	5	S1 Format	16
Environmental Type A	5	Motion Detector Programming	17
Environmental Type B	5	PROGRAM DESCRIPTIONS	18
Environmental Type C	5	Sensor Installation	18
Chime Only Zone	5	TK-90 Wireless Keypads	18
Automation #1	5	Accessory (Keypad) Installation	24
Automation #2	5	General Communicator Operation	26
Access Only	5	Communicator Routing, Telephone #'s & Account #'s	30
Tx Type Transmitter Button Disable Zone	5	Reporting Codes For All Formats Except SuperSpeed & SIA	34
SECURITY LEVELS	6	SuperSpeed, SIA & Ademco Contact ID Format Reporting Options	38
Programming Level (For Installers Only)	6	Reporting Codes for Extended Formats SuperSpeed, SIA & Ademco Contact ID Format Reporting Codes	40
Test Levels	6	Personal Access Code (PAC) Installation	42
Disarm/Cancel and Low Security Levels	6	Changing PACs Outside of Level 9	43
High Security Arming Levels	6	Changing Temporary PAC Outside of Level 9	43
KEYPAD SOUNDS	7	Control Panel Configuration	44
Audible Signals and Sirens	7	Special Installer Functions	48
KEYPAD COMMANDS	8	SYSTEM TESTING	49
Status Key Commands	8	Level 7 Telephone Test	49
Special Keypad Commands	8	Level 8 Sensor Test	49
TROUBLE DISPLAYS	9	INDEX	50
Sensor Trouble Codes	9	REGULATORY INFORMATION	51
Control Panel Trouble Codes	9	LINEAR LIMITED WARRANTY	52
Internal System Trouble Codes	9	NOTES	53

PROGRAMMING OUTLINE

The following outline is intended to guide the alarm installer through the programming of a CP-90 system.

If you don't read anything else, read this outline!

Use the following outline in conjunction with this copy of the CP-90 Programming Instructions to guide you through the CP-90 installation.

Because of the many programming options of the CP-90, thoroughly reading this manual is very important. Understanding the CP-90 programming structure will result in many saved hours during the installation.

1. Hold the **MASTER RESET** switch down and turn the **MASTER POWER** switch on while still holding down the **MASTER RESET** switch. Wait up to 45 seconds while still holding down the MASTER RESET switch. You should hear a relay click then chatter. The system now has the factory defaults installed.

☛ **NOTE:** The keypads will reset after the master reset of the control panel is complete.

2. Close the control panel door.
3. Check that all of the keypads are running; the green **POWER** light should be lit on each one.
4. Press "STATUS 97" to clear trouble displays. 
5. Read the "Control Station Overview", "System Zones" and "Security Levels" sections of this manual to learn how to use the system.
6. Program the CP-90.
 - A. Fill out the "CP-90 Programming Worksheet" with the desired values for the system.
 - B. Thoroughly review the "Programming Overview" section of this manual.
 - C. Execute program Function 21 to install all wired keypads.
 - D. Program the keypad(s) lighting and sound levels using the "Accessory Installation Table" (Functions 24-35).
 - E. Program the first part of the communicator using the "General Communicator Operation Table" (Functions 50-51). **Leave the communicator turned off (Function 050.001) until installation is complete.**
 - F. Program any special reporting codes (if different from the defaults). Use the correct "Reporting Codes Table" (Functions 70, 72, 74, 75, 77 & 79) for the communicator format(s) being used.
 - G. Program the rest of the communicator using the "Communicator Routing, Telephone #'s and Account #'s Table" (Functions 60-69).
 - H. Program the personal access codes (PAC) using the "Personal Access Code (PAC) Installation Table" (Functions 90-101). Write the codes on the CP-90 User's PAC Card.
 - I. Program the exit/entry delays and other options using the "Control Panel Configuration Table" (Functions 120-121).
 - J. Program the wireless and hardwired sensors using the "Sensor Installation Table" (Functions 0-17). **Be sure to perform steps 6E & 6F before performing this step.**
 - K. Fill out the user's "Sensor Number Card" with types and locations of sensors.
7. Test the system locally.
8. Turn the communicator on by programming Function 050.001 to a value of 1 (if system is monitored).
9. Test the system again, verifying that the central station receives the correct report codes.
10. Instruct the user on system operation.

SYSTEM POWER-UP

FIRST TIME POWER-UP

If the unit is new out-of-the-box, just turn the MASTER POWER switch on. The factory loaded defaults are already installed in memory.

RESTORING FACTORY DEFAULTS

If the unit has previously been programmed, and you want to reset the system back to the factory defaults, follow these steps:

- STEP 1** Be sure the MASTER POWER switch is off (see Figure 1 for switch location).
- STEP 2** Use a small tool to press and hold down the MASTER RESET switch.
- STEP 3** Turn the MASTER POWER switch on while still holding down the MASTER RESET switch. Wait up to 45 seconds while still holding down the MASTER RESET switch. You should hear a relay click then chatter. The system now has the factory defaults installed.

INTERNAL Diagnostic Checks

The CP-90 performs an automatic internal diagnostic check when the system is first powered up. The system checks itself to be sure everything is in order. The internal check takes about 10 seconds. If something is wrong, the keypad's TROUBLE LED will flash and a supervisory condition will occur. Press the STATUS button for one second to display the condition.

NOTE: When the system is first powered up, the keypad's TROUBLE light may flash. Press "STATUS 97" to clear the indication before proceeding.

WATCHDOG MONITOR

While the system is operating, an internal "watchdog" circuit monitors the system. If for some reason (lightning strike, etc.) the system's memory is upset, the watchdog monitor will reset the system, restoring system integrity. If a watchdog reset occurs, the keypad's TROUBLE light will flash and a "Supervisory Condition 89" will occur. The security level will remain at the previously set level.

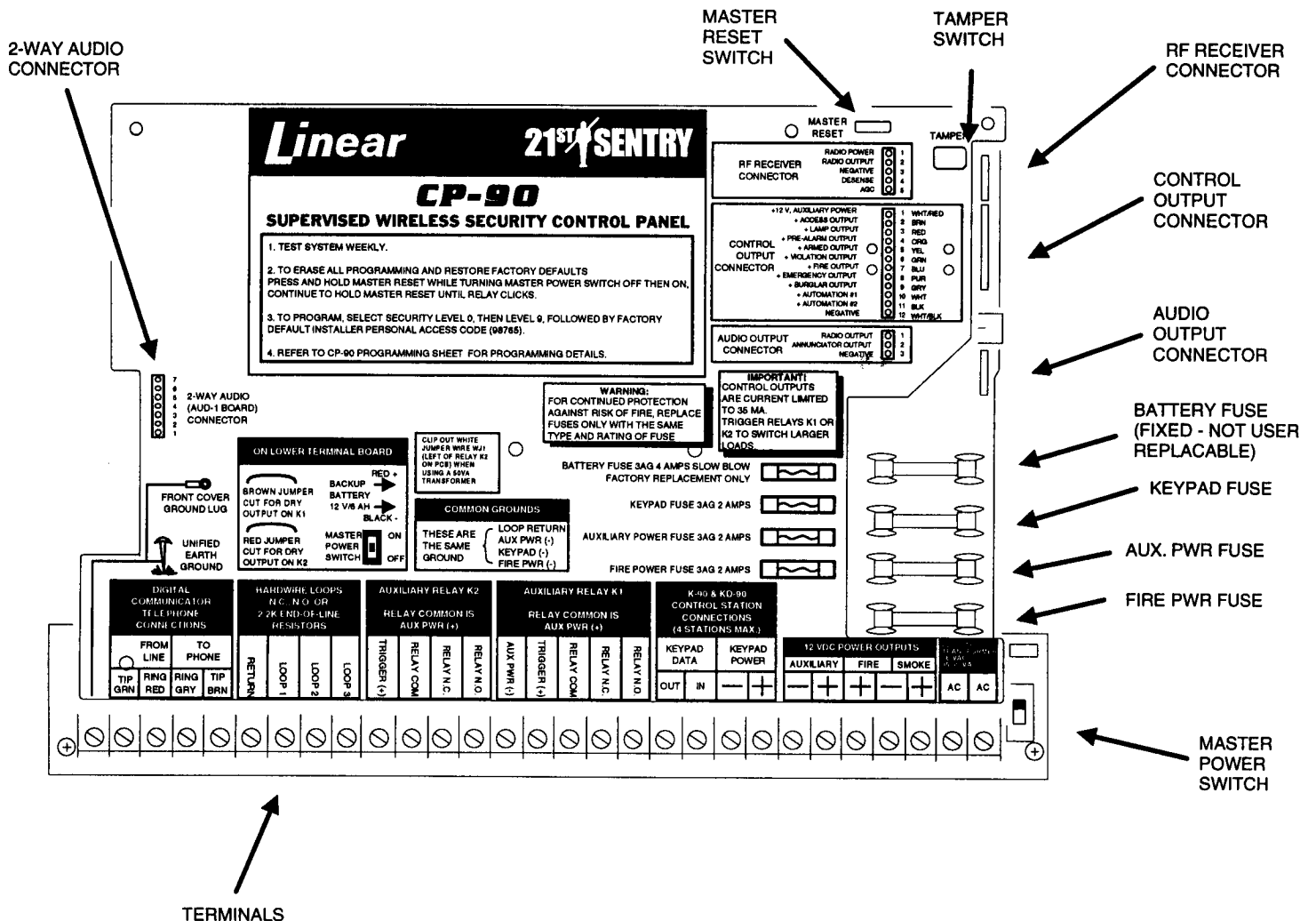

Figure 1. CP-90 Parts Locator

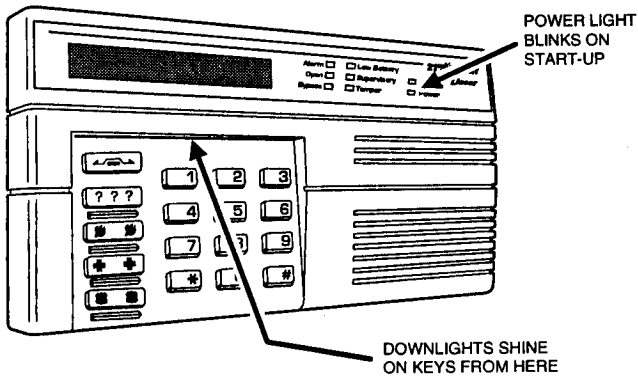

Figure 2. KD-90 Keypad

POWER-UP INDICATIONS

When the CP-90 MASTER POWER switch is turned on, the keypad's POWER LED will blink until the CP-90 initializes the keypads. This takes about 10-20 seconds.

NOTE: When the system is first powered up, the keypad's TROUBLE light may flash. Press "STATUS 97" to clear the indication before proceeding.

Keypad Lighting

Each keypad (except the wireless TK-90) has programmable downlights that light up the keys and programmable display lighting. Each keypad in the system can be programmed for different lighting levels. An active level is set when the keypad is in use. A standby level is set when the keypad is idle.

The keypad will automatically assume standby lighting level after 45 seconds of inactivity.

Keypad Supervision

Every minute, each wired keypad is checked by the CP-90 to be sure that it's still there. If the control finds a keypad missing, a "Supervisory Condition" will occur. Remaining keypads can display the condition and a central station trouble report will be sent (if programmed for that type of report).

Keypad Lockout Timer

Control station keypads have a five second timer that automatically locks out further keypad entries after an incorrect command sequence or access code is entered. The control station will automatically unlock five seconds after the last keystroke. At any time during a keystroke sequence, the keypad and display may be reset, unlocked and cleared by pressing the * key.

NOTE: If the keypad doesn't seem to respond to your commands, press * before entering the command again.

PROGRAMMING LEVEL TIMER

While programming the CP-90 from a keypad, if no keystrokes are made for four minutes, the system will automatically leave the programming level mode.

CONTROL STATION OPERATION

Refer to the CP-90 User's Guide (P/N 207417) for complete details on system and control station operation. The following pages of this manual contain some basic CP-90 system information that should be understood before programming the CP-90.

SYSTEM ZONES

This page is similar to the information presented in the CP-90 User's Guide. This general information is presented so that the installer can become familiar with the CP-90's zones.

Each sensor installed in the system is programmed to a specific "sensor number" and "sensor zone".

The *sensor number* (01-64) identifies the specific sensor when displayed on the keypad(s) and to the central monitoring station (if system is monitored). This allows pin-point information about any sensor in the system.

The *sensor zone* determines how and when the Control Panel responds to signals from the sensor. Some sensors are armed all the time, others are armed only in certain security levels. Some sensors cause central station reports in certain security levels, some cause central station reports anytime their activated. The sensor's programmed zone along with other programming options determines this.

The sensor zones are:

EXTERIOR

For perimeter doors and windows.

INTERIOR

For motion detectors, mat switches, interior doors and other sensors that detect human presence inside the building.

RESTRICTED INTERIOR

For special interior areas that are not normally occupied during nighttime. Sensors used in this zone would be located in an attic, basement, inside a detached garage or other similar areas.

FIRE

Continuously armed 24-hour zone for smoke detectors, heat sensors, pull stations, etc. Can also be triggered directly from keypad.

EMERGENCY

Continuously armed 24-hour zone for personal or other types of emergencies. Can also be triggered directly from keypad.

Police/Hold-up

Continuously armed 24-hour zone for panic, police or hold-up. Can also be triggered directly from keypad.

ARM/DisARM Toggle

++ Sensors programmed to this zone can arm and disarm the system. This zone alternately arms the system to Level 4 and disarms the system to Level 1. Automatic bypassing occurs if other sensors are open. Hardwire loops can be programmed to this zone for keyswitch use.

Delayed Remote Emergency

Continuously armed 24-hour zone for personal or other types of emergencies. Portable sensor must be activated for 3 seconds to trigger emergency alarm. ST-1 transmitters cannot be used for this zone because they only transmit for 1 second. Use an LMT-1, TX-91, TX-92 or TX-94.

☞ **NOTE: LMT-1 Not tested by UL for emergency signaling.**

Delayed Remote Police/Hold-up

Continuously armed 24-hour zone for panic, police or hold-up. Portable sensor must be activated for 3 seconds to trigger panic alarm. ST-1 transmitters cannot be used for this zone because they only transmit for 1 second. Use an LMT-1, TX-91, TX-92 or TX-94.

☞ **NOTE: LMT-1 Not tested by UL for emergency signaling.**

☞ **NOTE: ++ Indicates a supplementary zone type for UL Listed residential fire, Grade "A" burglar alarm and home health care systems.**

GUARD ZONE

++ For protecting areas or objects that are not normally entered or moved when the burglary portion of the system is disarmed. Used for gun cabinets, artworks, museum pieces, liquor cabinets, etc. This zone is also suitable for glass break sensors. Local alarm will sound when this zone is armed; causes central station reports in Level 4 only.

ENVIRONMENTAL Type A

++ Continuously armed 24-hour zone for environmental sensors (flood, freeze, etc.). Causes local annunciation, alarm and central station reports.

ENVIRONMENTAL Type B

++ Continuously armed 24-hour zone for environmental sensors (flood, freeze, etc.). Causes local annunciation and alarm but no central station reports.

ENVIRONMENTAL Type C

++ Continuously armed 24-hour zone for environmental sensors (flood, freeze, etc.). Causes local annunciation only.

Chime Only Zone

++ This zone causes a local chime when triggered. Can be used for wireless doorbell, mailbox mail detector, driveway vehicle sensor, etc. Active 24-hours in Security Levels 1, 2 and 3.

AUTOMATION #1

++ Sensors programmed for this zone cause the Automation Output #1 to activate on the control output connector. Output may be timed or toggle on/off (programming option).

AUTOMATION #2

++ Sensors programmed for this zone cause the Automation Output #2 to activate on the control output connector. Output may be timed or toggle on/off (programming option).

ACCESS Only

++ Sensors programmed for this zone cause the Access Output to activate on the control output connector. Output may be timed or toggle on/off (programming option).

Tx Type Transmitter Button Disable Zone

This is a special zone used to disable desired buttons on TX type portable transmitters. This special zone disables unneeded transmitter buttons on multi-button transmitters.

SECURITY LEVELS

This page is similar to the information presented in the CP-90 User's Guide. This general information is presented so that the installer can become familiar with the CP-90's security levels. The CP-90 System can be armed (or disarmed) to different levels of security protection. Each security level arms or disarms a specific group of sensor zones.

The security levels are named after their most common use. When changing to a security level, the keypad will sound a level change gong then count a number of beeps (in groups of three) to match the selected level. The security levels are:

PROGRAMMING LEVEL (FOR INSTALLERS ONLY)

LEVEL 9 PROGRAMMING MODE (Gong & 9 beeps)

- Used to program the system from a keypad.
- Allows reviewing and changing of the program Functions, Selectors and Values.
- Press and hold the "*" key for 5 seconds to exit program mode.
- Mode exits automatically after 4 minutes of inactivity.

TEST LEVELS

LEVEL 7 PHONE TEST (Gong & 7 beeps)

- Level 7 sends a telephone "test" message to the central monitoring station (if system is monitored).
- All intrusion detection is off.
- All 24-hour sensors (fire, panic and environmental) are armed.
- Upon successful phone test, keypad will sound accept tones and the system will return to Level 0.

LEVEL 8 SENSOR TEST (Gong & 8 beeps)

- Used to test each of the system's sensors.
- Activating sensor causes keypad beep.
- Display shows sensors that need to be tested.
- Pressing the STATUS button displays last sensor activated.
- Press STATUS again to resume displaying sensors to be tested.

DISARM/CANCEL AND LOW SECURITY LEVELS

LEVEL 0 DISARM/CANCEL (Gong only)

- All intrusion detection is off.
- All 24-hour sensors (fire, panic and environmental) are armed.
- Disarms system (cancels any alarm in progress).

LEVEL 1 GUARD/CANCEL (Gong & 1 beep)

- Guard Zone is armed (gun cabinet, safe, etc.) and will cause a local alarm only.
- All intrusion detection is off.
- All 24-hour sensors (fire, panic and environmental) are armed.
- Chime Only Zone is active.
- Disarms system (cancels any alarm in progress).

LEVEL 2 CHIME (Gong & 2 beeps)

- A two-tone "chime" will sound whenever windows or an exterior door is opened.
- Guard Zone is armed (gun cabinet, safe, etc.) and will cause a local alarm only.
- All intrusion detection is off.
- All 24-hour sensors (fire, panic and environmental) are armed.
- Chime Only Zone is active.

High SECURITY ARMING Levels

LEVEL 3 HOME (Gong & 3 beeps)

- All windows and exterior doors are armed.
- All interior sensors are off.
- Delayed sensors allow "Secure Entry" when the user enters a PAC and rearms to Level 3, 5 or 6 during the entry delay.
- "Secure Exit" starts an exit delay for delayed sensors when the user enters a PAC and rearms to Level 3 from Level 3.
- Guard Zone is armed (gun cabinet, safe, etc.) and will cause a local alarm only.
- All 24-hour sensors (fire, panic and environmental) are armed.
- Chime Only Zone is active.

LEVEL 4 AWAY (Gong & 4 beeps)

- All sensors (interior and exterior) are armed.
- Delayed sensors allow timed exit and entry of premises without sounding an alarm.
- Guard Zone is armed (gun cabinet, safe, etc.) and will cause a local alarm and central station reports.
- All 24-hour sensors (fire, panic and environmental) are armed.

LEVEL 5 NIGHT (Gong & 5 beeps)

- All windows and exterior doors are armed.
- Delayed sensors allow "Secure Entry" when a user enters a PAC and rearms to Level 3, 5 or 6 during the entry delay.
- "Secure Exit" starts an exit delay for delayed sensors when the user enters a PAC and rearms to Level 5 from Level 5.
- Restricted interior sensors are armed (garage, downstairs interiors, other areas not normally entered at night).
- Guard Zone is armed (gun cabinet, safe, etc.) and will cause a local alarm only.
- All 24-hour sensors (fire, panic and environmental) are armed.

LEVEL 6 NIGHT SECURE (Gong & 6 beeps)

- All windows and exterior doors are armed as instant.
- Delayed sensors activate as "instant" unless "Secure Exit" is used.
- The system must be disarmed prior to entry or an instant alarm will occur.
- "Secure Exit" starts an exit delay for delayed sensors when the user enters a PAC and rearms to Level 6 from Level 6.
- Restricted interior sensors are armed (garage, downstairs interiors, other areas not normally entered at night).
- Guard Zone is armed (gun cabinet, safe, etc.) and will cause a local alarm only.
- All 24-hour sensors (fire, panic and environmental) are armed.

SECURITY LEVEL ARMING TABLE							
	LEVEL 0	LEVEL 1	LEVEL 2	LEVEL 3	LEVEL 4	LEVEL 5	LEVEL 6
✓ = ARMED * = ARMED INSTANT ▲ = CHIMES							
EXTERIOR			▲	✓	✓	✓	*
INTERIOR					✓		
RESTRICTED INTERIOR					✓	✓	✓
FIRE	✓	✓	✓	✓	✓	✓	✓
EMERGENCY	✓	✓	✓	✓	✓	✓	✓
POLICE/HOLD-UP	✓	✓	✓	✓	✓	✓	✓
REMOTE EMERGENCY	✓	✓	✓	✓	✓	✓	✓
REMOTE POLICE/HOLD-UP	✓	✓	✓	✓	✓	✓	✓
GUARD ZONE		✓	✓	✓	✓	✓	✓
ENVIRONMENTAL TYPE A	✓	✓	✓	✓	✓	✓	✓
ENVIRONMENTAL TYPE B	✓	✓	✓	✓	✓	✓	✓
ENVIRONMENTAL TYPE C	✓	✓	✓	✓	✓	✓	✓
CHIME ONLY		▲	▲	▲			

Figure 3. Security Level Arming Table

KEYPAD SOUNDS

This page is similar to the information presented in the CP-90 User's Guide. This general information is presented so that the installer can become familiar with the CP-90's keypad sounds.

Audible Signals and Sirens

Audible signals are used to sound system status, alert the user of an emergency and frighten away an intruder. The sounds come from the speakers in the hardwire keypads. The different sounds are:

Emergency Fire Alarm

Loud, rapid two-tone siren.

Emergency Intrusion Alarm

Loud, intermittent siren.

Personal Emergency Sounder

A two-tone high/low chime sound.

Police/Hold-up Emergency Alarm

Loud, high/low siren sound.

Environmental Alarm Sounder/Trouble Sounder

A short, single-tone triple beep repeated at 1 minute intervals. This sound is used for environmental alarms and for sensor/accessory low battery or supervisory trouble (Function 121.022). Silence by pressing the * key.

Accept Tones

A three-tone sound which indicates that the system has accepted a command.

Rejection Tones

Low volume, short two-tone sound which sometimes occurs when a keypad command is entered. It indicates that the command was not directly accepted. Normally this occurs when trying to arm the system with an open sensor. The sensor(s) must be closed or bypassed, then the system will arm.

Exit Delay Beeps

Short, single-tone beeps repeated at 1 second intervals during the exit delay. An exit delay allows time for you to leave the premises through a door programmed as "delayed". **The premises must be vacated before the exit delay time expires or an alarm will occur.**

Entry Delay Beeps

Short, single-tone beeps repeated at 1/2 second intervals during the entry delay. Entering the protected premises through an exterior door programmed for "delay" will start the entry beeps. **The system must be disarmed before the entry delay time expires or an alarm will occur.**

Entry Delay After Alarm Beeps

Short, two-tone beeps repeated at 1/2 second intervals during the entry delay after an alarm has occurred. **This is to alert you to exercise caution when entering the premises, as the intruder may still be present.**

Level Change Gong

A single gong tone sound that occurs after changing security levels.

Level Count Beeps

Short, low volume single-tone beeps that come after a level change gong or when the STATUS key is pressed. Count the number of beeps to determine the current security level.

Chime Tones

Low volume two-tone chime which indicates a door or window sensor has been opened when the system is armed in Level 2. Also used as sounder for the Chime Only Zone.

Sensor Test Beep

Loud single-beep heard when testing the sensors in Level 8 (Sensor Test Mode).

Ready to Learn Sensor Tone

Low volume two-tone chime which indicates that the CP-90 is ready to learn one or more RF sensors (Functions 001, 002 & 017 only).

Panel Connection Warning Chirps

If the keypad sounds continuous chirps, there is trouble in the connection between the keypad and the control panel. Check the keypad cable if this occurs.

KEYPAD COMMANDS

This page is similar to the information presented in the CP-90 User's Guide. This general information is presented so that the installer can become familiar with the CP-90's keypad commands.

STATUS Key Commands



The STATUS key has four functions:

- ☞ If the STATUS key is pressed on a wireless keypad (keypad with no display), the current security level count beeps will sound from the hardwired keypads.
- ☞ If the STATUS key is pressed on a wired keypad (keypad with display), the current security level count beeps will sound and the display will show "— —". A sensor number or special keypad command can be entered. Entering a sensor number displays the current state of that sensor. Enter two digits (04 = Sensor #4).
- ☞ If the STATUS key is pressed and held for about 1 second, the display will cycle to show the status of all of the sensors. If all sensors are closed and no trouble conditions exist, the display will show ". ." on the K-90 or "SYSTEM READY" on the KD-90.
- ☞ If the STATUS key is pressed during the status display cycle, the display will freeze on the sensor displayed. Press STATUS again to restart the display cycling.

After using the STATUS key, the display will return to normal after 45 seconds of keypad inactivity.

Special Keypad Commands

Special keypad commands are used for resetting functions and performing system tests. **The system must be in Level 0 to use these commands.** The special keypad commands are:

KD-90 Keypad Commands

- ☞ Press STATUS then "80"
Sets clock minutes - enter two digits (01 = 1).
- ☞ Press STATUS then "81"
Sets clock hours - enter two digits (01 = 1).
- ☞ Press STATUS then "82"
Sets calendar day - enter two digits (01 = 1).
- ☞ Press STATUS then "83"
Sets calendar month - enter two digits (01 = 1).
- ☞ Press STATUS then "84"
Sets calendar year - enter two digits (01 = 1).
- ☞ Press STATUS then "85"
Sets day of week - enter 01-07 (01=Sunday).
- ☞ Press STATUS then "86"
Adjusts clock 1 second per day faster.
- ☞ Press STATUS then "87"
Adjusts clock 1 second per day slower.

KD-90 or K-90 Keypad Commands

- ☞ Press STATUS then "90"
Displays version of CP-90 firmware.
- ☞ Press STATUS then "96"
Displays alarm memory of up to nine alarm events in order of occurrence.
- ☞ Press STATUS then "97"
Clears all trouble displays on the keypad.
- ☞ Press STATUS then "98"
Starts a manual system backup battery test.
- ☞ Press STATUS then "99"
Resets latching wired smoke detectors.

TROUBLE DISPLAYS

This page is similar to the information presented in the CP-90 User's Guide. This general information is presented so that the installer can become familiar with the CP-90's trouble codes.

Special situations will cause the TROUBLE light on the keypad(s) to blink. To identify the trouble, press and hold the STATUS key for one second. To clear troubles, fix the problem and press "STATUS 97" from Level 0.

On a K-90 keypad, view the supervisory code number on the sensor display and watch for the corresponding light indicating the type of trouble.

On a KD-90 keypad the display will show a "Supervisory Code" listed on the first line of the display and the trouble condition listed on the second line of the display.

The system can identify trouble from three areas: Sensors and accessories (RF transmitters, hardwired loops and wired keypads), the control panel hardware (fuses, tamper, backup battery and AC power) and internal system functions (radio decoding, EEPROM memory and watchdog circuitry).

SENSOR Trouble Codes

The table in Figure 4 shows the possible trouble codes that occur from sensors. These kind of trouble conditions can be corrected by taking the actions shown in the table.

CONTROL PANEL Trouble Codes

The table in Figure 5 shows the possible control panel trouble codes that might occur. These kind of trouble conditions can be corrected by the installer by replacing blown fuses and correcting the problem, etc.

SENSOR TROUBLE CODES (xx = SENSOR NUMBER)			
CODE #	DISPLAY DESCRIPTION	CAUSE	ACTION
4-64	SENSOR xx LOW BATTERY (Accompanied by an audible trouble warning in UL systems.)	Sensor has sent a low battery signal.	Replace battery in sensor number displayed. Trouble clears when sensor's battery is replaced.
4-64	SENSOR xx SUPERVISORY (Accompanied by an audible trouble warning in UL systems.)	Sensor has not reported to CP-90 in eight hours. May be caused by a missing or inoperative sensor or a radio reception problem.	Check the sensor's condition. Try the EXA-1000 remote antenna if reception is a problem.
1-64	SENSOR xx TAMPER	Sensor case has been opened and tamper has been reported to the CP-90.	Check the sensor's condition. Trouble indication must be cleared with "STATUS 97".
65-72	ACCESSORY xx SUPERVISORY (Accompanied by an audible trouble warning in UL systems.)	Accessory (keypad) has not reported to CP-90 in one minute. May be caused by an inoperative or missing keypad.	Check the keypad's condition. Check the keypad wiring.
65-72	ACCESSORY xx TAMPER	Accessory (keypad) has been removed from its mounting plate.	Check the keypad's condition. Trouble indication must be cleared with "STATUS 97".

Figure 4. Sensor Trouble Codes

CONTROL PANEL TROUBLE CODES			
CODE #	DISPLAY DESCRIPTION	CAUSE	ACTION
73	SUPERVISORY CODE 73 COMMUNICATION FAILURE	CP-90 has failed to fully connect to the central station after all call attempts.	Check the telephone connection. Check the telephone line.
74	SUPERVISORY CODE 74 PANEL LOW BATTERY	CP-90 has a low or missing control panel backup battery.	Check battery fuse, battery charge voltage and battery condition. May have been caused by lack of AC power.
75	SUPERVISORY CODE 75 PANEL AUXILIARY FUSE FAILURE	CP-90 auxiliary power fuse is blown or missing. Too much current has been drawn from auxiliary power output.	Replace auxiliary power fuse with a 2 Amp fuse.
76	SUPERVISORY CODE 76 PANEL FIRE FUSE FAILURE	CP-90 fire power fuse is blown or missing. Too much current has been drawn from fire power output.	Replace fire power fuse with a 2 Amp fuse.
78	SUPERVISORY CODE 78 PANEL POWER FAILURE	CP-90 has had a complete loss of AC and DC power.	Be sure transformer is connected to an unswitched outlet that provides power 24 hours-a-day.
79	SUPERVISORY CODE 79 PANEL TAMPER CONDITION	The CP-90 control panel cabinet has been opened.	Close the control panel door and reset the trouble indication with "STATUS 97".
80	SUPERVISORY CODE 80 PANEL AC POWER FAILURE	CP-90 has had a loss of AC power.	Be sure transformer is connected to an unswitched outlet that provides power 24 hours-a-day.
87	SUPERVISORY CODE 87 UNINSTALLED ACCESSORY	A keypad has been wired to the CP-90 but has not been installed into the system memory.	See Programming Instructions for how to install accessories with Function 21.

Figure 5. Control Panel Trouble Codes

INTERNAL SYSTEM Trouble Codes

The table in Figure 6 shows the possible internal system trouble codes that might occur under rare system conditions. If these kind of trouble codes show up more than once, call the Linear Technical Services Department for instructions.

INTERNAL SYSTEM TROUBLE CODES			
CODE #	DISPLAY DESCRIPTION	CAUSE	ACTION
77	SUPERVISORY CODE 77 PANEL RADIO FAILURE	The CP-90 has detected a problem in the radio receiver circuitry.	Call Technical Services if this happens more than once.
86	SUPERVISORY CODE 86 PANEL RAM CHECK ERROR	The CP-90 has detected a RAM memory error.	
88	SUPERVISORY CODE 88 EEPROM WRITE FAILURE	The CP-90 has detected an error when updating its memory.	
89	SUPERVISORY CODE 89 WATCHDOG MONITOR RESET	The CP-90 has detected abnormal operation of the control panel software and has restarted itself.	

Figure 6. Internal System Trouble Codes

PROGRAMMING OVERVIEW

PROGRAM FUNCTIONS

Each programming step for the CP-90 has a *Function* number. The Function numbers start at 0 and end at 121. Each Function number programs a separate feature of the CP-90 (i.e. central station telephone number, central station account number, etc.). Figure 7 shows two Function numbers (62 & 63).

FUNCTION	DESCRIPTION
62	PRIMARY LINE TELEPHONE NUMBER
63	PRIMARY LINE ACCOUNT NUMBER

Figure 7. Each Programming Step has a Function Number

PROGRAM SELECTORS

Most of the Function numbers require programming more than one entry. The second number to be entered is called the *Selector*.

For example, Function 62 is the Primary Line Telephone Number. The telephone number can have up to 24 digits. Each telephone number digit is identified by a Selector number. Function 62 uses Selectors 1-24 to identify each of the telephone number digits, 1 = the first digit, 2 = the second digit and so on (See Figure 8).

FUNCTION	SELECTOR	DESCRIPTION
62	1-24	PRIMARY LINE TELEPHONE NUMBER

Figure 8. Program Functions have Selectors

PROGRAM VALUES

The third number to be entered is called the *Value*. Some Functions may not require a Value entry.

The range of valid Value numbers that can be entered for a given Function/Selector combination depends on the specific Function/Selector Chosen.

For example, Function 62 (Primary Line Telephone Number) has 24 Selectors that can be programmed with the telephone number digits (see Figure 9).

Each Selector can be programmed with Values of 0-15 (0-9 are telephone digits, 11-15 are special dialing codes).

FUNCTION	SELECTOR	VALUE	DESCRIPTION
62	1-24	0-15	PRIMARY LINE TELEPHONE NUMBER

Figure 9. Function's Selectors have Values

DEFAULT VALUES

Many of the CP-90's programming Functions have Selector Values already set at the factory. These are called the "Factory Default Values".

The Factory Default Values are typical settings used in most security systems (exit/entry delays, alarm cutoffs, etc.). Most of these pre-programmed Values will not have to be changed by the installer.

For example, the default value for the Fire Output cutoff time is 5 minutes. The programming step is Function 120, Selector 6. The default Value is pre-set at 5 and can be changed to a new Value from 0 to 250 (see Figure 10).

Using the factory defaults speeds up programming the CP-90. The commonly used defaults are shown in Figure 11. Refer to the CP-90 Programming Key for all of the default values.

FUNCTION	SELECTOR	VALUE	DEFAULT	DESCRIPTION
120	6	0-250	5	FIRE OUTPUT CUTOFF TIME IN MINUTES

Figure 10. Default Value of 5 for Fire Alarm Cutoff

NOTATION FOR FUNCTIONS, SELECTORS & VALUES

In this manual, when a programming Function is shown the format "Function FFF" is used, where:

FFF = the Function Number
(i.e. Function 120).

When a specific Function and Selector are shown the format "FFF.SSS" is used, where:

FFF = the Function number
SSS = the selector number.
(i.e. 120.006)

When a specific Function, Selector and Value are shown the format "FFF.SSS.VVV" is used, where:

FFF = the Function number
SSS = the selector number
VVV = the value number.
(i.e. 120.006.005)

For example, 120.006.005 is the notation for Function 120, Selector 6, Value 5 (used in Figure 10).

FACTORY DEFAULTS & UL PROGRAMMING REQUIREMENTS

FACTORY SET DEFAULTS	
FEATURE	DEFAULT
HARDWIRE LOOP RESPONSE TIME	400 MILLISECONDS
KEYPAD EMERGENCY KEYS	ALL ENABLED
ACTIVE DISPLAY INTENSITY	MEDIUM
ACTIVE DOWNLIGHT INTENSITY	MEDIUM
STANDBY DISPLAY INTENSITY	OFF
STANDBY DOWNLIGHT INTENSITY	OFF
KEYPAD LIGHTS DURING ENTRY DELAY	ON
KEYPAD LIGHTS DURING EXIT DELAY	ON
DIGITAL COMMUNICATOR	DISABLED
DIALING FORMAT	TONE
DIALING ATTEMPTS BEFORE ROUTING CHANGE	2
DIALING ATTEMPTS BEFORE SLEEP CYCLES	2
NUMBER OF SLEEP CYCLES	2
SLEEP CYCLE TIME	10 MINUTES
ANTI-JAM TIME	40 SECONDS
AUTOMATIC TEST REPORTS	DISABLED
MANUAL TEST REPORTS	ENABLED (FOR SUPERSPEED ONLY)
INSTALLER PAC	98765
ENTRY DELAY TIME #1	30 SECONDS
ENTRY DELAY TIME #2	45 SECONDS
EXIT DELAY TIME	45 SECONDS
BURGLARY OUTPUT CUTOFF	5 MINUTES
FIRE OUTPUT CUTOFF	5 MINUTES
EMERGENCY OUTPUT CUTOFF	5 MINUTES
ACCESS OUTPUT ON-TIME	5 SECONDS
AUTOMATION OUTPUT #1 ON-TIME	5 SECONDS
AUTOMATION OUTPUT #2 ON-TIME	5 SECONDS
FIRE OUTPUT	PULSING
BURGLARY OUTPUT	CONSTANT
ENTRY DELAY KEYPAD BEEPS	ON
EXIT DELAY KEYPAD BEEPS	ON
QUICK ARMING	ENABLED
AUTOMATIC RESTORAL	BYPASSES CLEAR ON RESTORAL
AUTO BYPASS ARMING	AUTO BYPASS THEN ARM
REMOTE PROGRAMMING LOCKOUT	REMOTE ACCESS ENABLED
REMOTE ACCESS CODE	987654
AUDIBLE SENSOR TROUBLE	DISABLED
24 HR SYSTEM STATUS DISPLAY	DISABLED

Figure 11. Factory Default Value Settings
(Partial listing, see CP-90 Programming Key for all defaults)

Home Health Care Signaling UL Requirements

At least one of the reporting telephone numbers must be programmed to transmit medical panic alarm signals off-premises to the Listed Linear Model 3000R central station receiver. Also, zone and panel trouble events shall be programmed to report to the central station.

GENERAL UL PROGRAMMING REQUIREMENTS	
FEATURE	VALUE
BELL CUTOFF (120.005, 120.006, 120.007, 120.008)	4 MINUTES MINIMUM
DIALING DELAY (050.008)	45 SECONDS MAXIMUM
DIAL ATTEMPTS BEFORE SLEEP CYCLE (050.010)	5 TO 10
NUMBER OF SLEEP CYCLES ALLOWED (050.011)	1
ANTI-JAM TIME (050.013)	3-7 SECONDS
SWINGER ELIMINATOR (050.015)	0 (ALL VIOLATIONS)
AUTOMATIC TEST REPORTS (070.017, 075.017 OR 072.004, 077.004 OR 074.004, 079.004)	ENABLED
AUTOMATIC TEST REPORT INTERVAL (050.018)	1 (24 HRS)
BELL OUTPUT DELAY (120.004)	0 SECONDS
RECEIVER DESENSE (121.015)	0 (NORMAL)
24 HR SYSTEM STATUS DISPLAY (121.018)	1 (ACTIVE)
AUDIBLE SENSOR TROUBLE (121.022)	1 (AUDIBLE & VISUAL)
SENSOR SUPERVISION (007.004-064)	0 (SUPERVISED FOR ALL FIXED SENSORS)
LOOP RESPONSE TIME (012.001-003)	10 (1 SECOND)
REMOTE PROGRAMMING LOCKOUT	NO REMOTE PROG.
COMPATIBLE CENTRAL STATION FORMATS (UL TESTED WITH LINEAR 3000R)	10,20,40 PPS 3x1, 4x1, 4x2 3x1 EXTENDED SESCOA SUPERSPEED

UL PROGRAMMING REQUIREMENTS FOR RESIDENTIAL FIRE	
FEATURE	VALUE
FIRE OUTPUT (121.002)	STEADY
SENSOR LOCAL ALARM (008.001-064)	0 (AUDIBLE)
SENSOR BYPASSING (009.001-064)	1 (NO BYPASS ON ALL FIRE ZONES)
NOTE: HARDWIRED FIRE LOOPS NOT ALLOWED IN CP-90 UL INSTALLATIONS, USE WIRELESS SMOKE DETECTORS.	

UL PROGRAMMING REQUIREMENTS FOR RESIDENTIAL GRADE "A" BURGLARY		
FEATURE	VALUE	
MAXIMUM ENTRANCE DELAY (120.001-002)	45 SECONDS	
MAXIMUM EXIT DELAY (120.003)	60 SECONDS	
BURGLARY OUTPUT (121.001)	PULSING	
MULTIPLE BURGLARY OUTPUT SHUTDOWN (121.003)	0 (NO LIMITS)	
SILENT BURGLARY ALARMS (121.011)	0 (AUDIBLE)	
AUTO BYPASS ARMING (121.014)	1 (MUST BE MANUAL)	
QUICK BYPASS (121.023)	1 (MUST BE MANUAL)	
USER PAC PROGRAMMING	3 DIGITS MINIMUM	
SENSOR LOCAL ALARM (008.001-064)	0 (AUDIBLE)	
LOOP SUPERVISION CHOICES		
	FCTN #13	FCTN #14
NORMALLY CLOSED WITHOUT EOL RESISTOR	1	0
NORMALLY OPEN WITHOUT EOL RESISTOR	NOT ALLOWED	
NORMALLY CLOSED WITH EOL RESISTOR	0	2
NORMALLY OPEN WITH EOL RESISTOR	0	1

Figure 12. UL Programming Requirements

ENTERING PROGRAMMING MODE

**START
HERE**

- CP-90 IN LEVEL 0
- PRESS CLEAR
- PRESS NINE FOR LEVEL 9
- ENTER FIRST DIGIT OF INSTALLER PAC
- ENTER SECOND DIGIT OF INSTALLER PAC

- ENTER THIRD DIGIT OF INSTALLER PAC
- ENTER FOURTH DIGIT OF INSTALLER PAC
- ENTER FIFTH DIGIT OF INSTALLER PAC

DONE

ONE GONG AND NINE BEEPS WILL SOUND AS CP-90 GOES INTO LEVEL 9

Figure 13. Entering Programming Mode

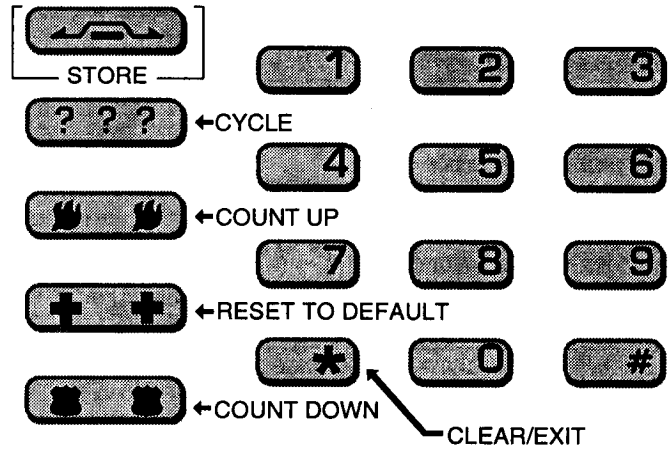

Figure 14. Control Station Keys During Programming

ENTERING PROGRAM LEVEL

Security Level 9 is for CP-90 programming. The installer access code default value is 98765 (see Figure 13).

To enter Level 9 follow these steps:

- STEP 1** Turn MASTER POWER switch on.
- STEP 2** Be sure system is in Level 0 (Level 9 can only be reached from Level 0). If system is not in Level 0 press 0 for Level 0, then 98765 to switch to Level 0.
- STEP 3** Enter 9 for Level 9, then 98765 to switch to Level 9.

NOTE: If the system does not respond to a keypad command, try pressing * to clear the keypad before entering the command again.

EXITING PROGRAMMING LEVEL

Hold the * key down for about 4 seconds to exit the program mode. This causes the system to leave Level 9 and go back to Level 0.

PROGRAMMING LEVEL TIMER

While programming the CP-90 from a keypad, if no keystrokes are made for **four** minutes, the system will automatically leave the programming Level 9 and return to Level 0.

CONTROL STATION KEYS DURING PROGRAMMING

When the system is in Level 9 the keypad keys perform different functions than normal (see Figure 14). A keypad template overlay (P/N 208247) is supplied with the CP-90 for placing over the keypad keys during programming. The template makes it easier to remember what functions the keys perform during programming.

BYPASS = STORE

Pressing the BYPASS key stores the displayed value into memory.

STATUS = CYCLE

Pressing the STATUS key cycles the display through the Function, Selector and Value fields.

1, 2, 3, 4, 5, 6, 7, 8, 9 & 0 KEYS

The number keys are used to enter Function, Selector and Value numbers directly.

FIRE = COUNT UP

Each time the FIRE key is pressed the displayed number (Function, Selector or Value) counts up by one.

EMERGENCY = RESET TO DEFAULT

Pressing the EMERGENCY key resets the displayed Value to the default number (factory value).

POLICE = COUNT DOWN

Each time the POLICE key is pressed the displayed number (Function, Selector or Value) counts down by one.

*** = CLEAR/EXIT**

Pressing * during programming clears the display and sends you back to Function 000, Selector 000. Use this key if the wrong key is pressed or if you're lost.

Holding the * key down for about 4 seconds causes the system to leave programming Level 9 and go back to Level 0.

PROGRAMMING Cycle

Programming is performed by setting three fields - Function, Selector and Value.

You can cycle through the fields by pressing the CYCLE (STATUS) key.

You can modify the displayed fields by using the keypad number keys or with the UP (FIRE) and DOWN (POLICE) keys. Pressing the * key at any time clears all three fields and returns the display back to the Function field.

When the Value field is displayed, pressing the DEFAULT (EMERGENCY) key replaces the displayed Value with the factory default Value.

KD-90 keypads display the Function, Selector and Value fields at the same time on the first line of the LCD display. The second line of the display is used to describe the current Function, display status or show data. The active field (the field that is being modified) is indicated by the flashing equal sign (=). See Figure 15.

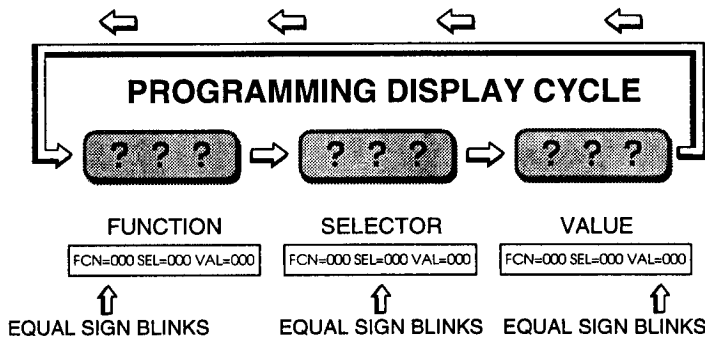

Figure 15. KD-90 Display During Programming

On K-90 keypads, read the LED display as a single, 3-digit number. The decimal point (.) location indicates whether the display is showing the Function, Selector or Value (see Figure 16).

For example:

- 1.20 reads as Function 120
- 0 0.6 reads as Selector 006
- 0 05. reads as Value 005

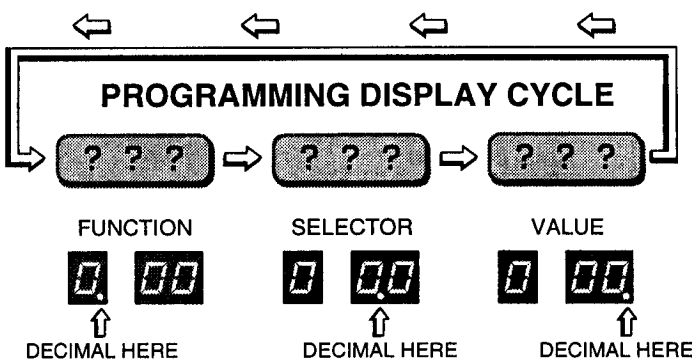

Figure 16. K-90 Display During Programming

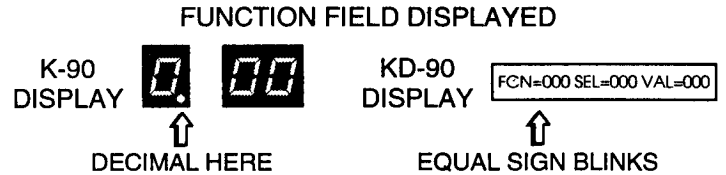

Figure 17. Displays Showing Function Field

FUNCTION Field

Enter the desired Function number and press CYCLE. If the keypad sounds the rejection tones and doesn't move to the Selector field, then the number in the Function field is out of range. This means that the Function number you have entered is not valid. Enter the correct number and press CYCLE again, or press the * key to clear the display and start over.

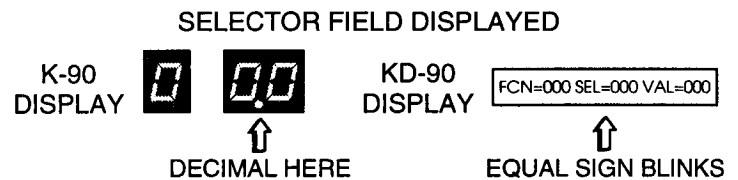

Figure 18. Displays Showing Selector Field

SELECTOR Field

Enter the desired Selector number and press CYCLE. If the keypad sounds the rejection tones and doesn't move to the Value field, then the number in the Selector field is out of range. This means that you have selected an invalid action, invalid sensor or the action you're attempting can't be performed. Enter the correct number and press CYCLE again, or press the * key to clear the display and start over.

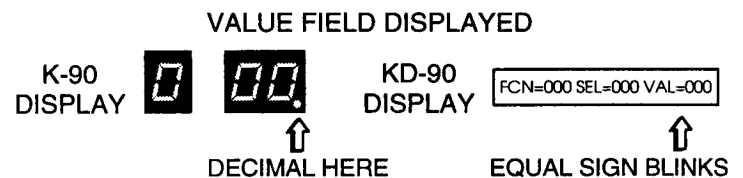

Figure 19. Displays Showing Value Field

VALUE Field

Once the Value field is displayed, pressing the STORE (BYPASS) key activates the function or stores the Value in memory. If no Value entry is required, pressing the STORE key is all that you need to do. If a Value entry is required, enter the new Value before pressing the STORE key; this will replace the current Value setting in memory with the new Value entered. **The Value field must be displayed before pressing the STORE key.** If you press the STORE key in any other field, the rejection tones will sound.

CHANGING VALUES

When the Value field is displayed or selected, the programmed Value can be changed to any number *within the range for that Value*. Use the CP-90 Programming Worksheet (P/N 207744) to decide which Values need to be changed.

The new Value will be displayed as it is entered on the keypad.

Remember, the new Value is not stored into the CP-90 memory until the STORE key is pressed and the *accept tones* sound. If the new Value is out of range or is entered incorrectly, the keypad will sound the *rejection tones*.

Figure 20 shows an example of changing the Fire Output cutoff from the default Value of 5 to a new Value of 10 minutes. The Function is 120, Selector is 6 and the new Value entered is 10.

NOTE: Pressing the * key will clear the previous selector to zero. If the previous selector is not in the range of valid selector numbers for the current function, it is set to the lowest valid number.

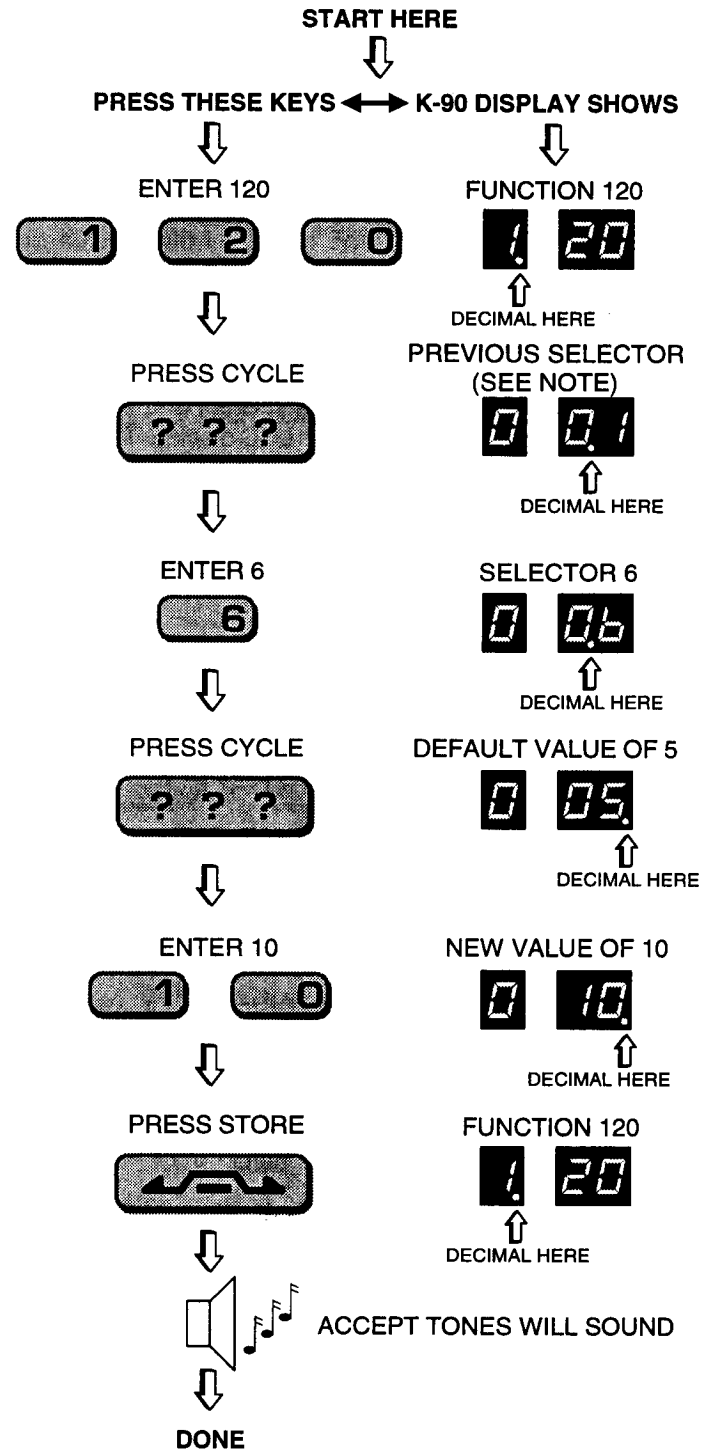

Figure 20. Example of Changing Fire Output Cutoff Time

CP-90 MEMORY LAYOUT

ABOUT SENSOR NUMBERS

The CP-90 system groups sensor numbers according to their type (see Figure 21). The sensor number groups are:

- 1-3 Hardwire Loops 1, 2 & 3
- 4-64 Wireless Sensors (61 maximum)
- 65-72 Control Stations (Keypads)

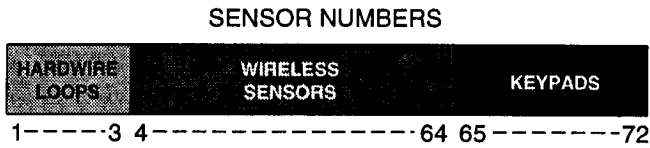

Figure 21. Sensor Number Groups

ABOUT CONTROL STATION NUMBERS

Control station (keypad) sensor numbers are always between 65 and 72. Wireless TK-90 keypads are programmed in as a wireless device and get a sensor number from 4-64. The CP-90 knows when a wireless TK-90 is installed so it also gives the TK-90 a keypad sensor number from 65 to 72 (see Figure 22). **Wireless TK-90 sensors will have an RF sensor number as well as a keypad accessory number. Always refer to the TK-90 by its accessory number.**

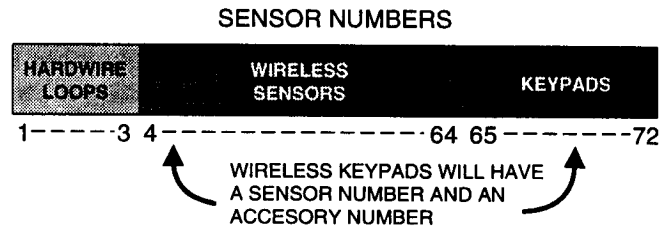

Figure 22. Wireless Keypad Sensor Numbers

SENSOR SETUP

Some of the sensors (transmitters) that are used with the CP-90 system must be set up to customize their installation. There are three radio formats that this system accepts. Each format's transmitters are set up in a different way.

NOTE: For complete details on installation and setup for each sensor type refer to the Installation Instructions provided with the sensor.

SX FORMAT

The T-90 door/window, TX series portable and TK-90 wireless keypad and all other SX format transmitters are pre-coded at the factory. There is no coding switch to set, although the T-90 does have an option switch (see Figure 23). The transmitters can be programmed into the CP-90 memory without any additional setup. These transmitters can be programmed into the CP-90 in manual or autoinstall mode by sending a test or violation transmission.

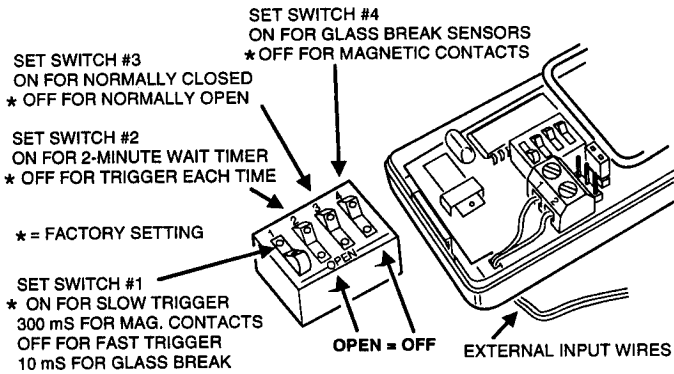
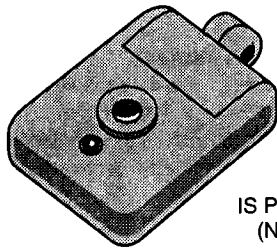

Figure 23. T-90 Option Switch

MegaCode FORMAT

The LMT-1 portable transmitter is pre-coded at the factory. There is no coding switch to set. The transmitter can be programmed into the CP-90 memory without any additional setup. This transmitter can be programmed into the CP-90 in the manual or autoinstall mode by pressing the transmitter button.

NOTE: LMT-1 not tested by UL.



MEGACODE
TRANSMITTER
IS PRE-PROGRAMMED
(NO CODE TO SET)

Figure 24. MegaCode LMT-1

S1 FORMAT

Linear's S1 format transmitters (ST, ST-1, 50S40A, ESL-371, ST-23A, 70S60) contain two eight-position switches. These switches are labeled CHANNEL and SYSTEM. The ST also contains a four-position option switch. These transmitters can be programmed into the CP-90 in manual or autoinstall mode sending a violation transmission or by holding the transmitter's test button for 3 seconds.

IMPORTANT NOTE: The CP-90 system does not require a specific "channel" or "system" code like Linear's previous supervised systems. **You can set the CHANNEL and SYSTEM switches in the S1 format transmitters to any code you like, as long as each transmitter used in the system is set to a different code.**

Consider the two eight-position switches as one big sixteen-position switch, allowing you set a unique code from over 65,000 possible combinations for each transmitter.

NOTE: Don't set the switches to all ON, all OFF, or alternating ON/OFF because it is too often duplicated.

NOTE: S1 transmitters were not tested by UL for burglary alarm requirements or emergency medical alarms.

SET CHANNEL AND
SYSTEM SWITCH TO
ANY UNIQUE
CODE

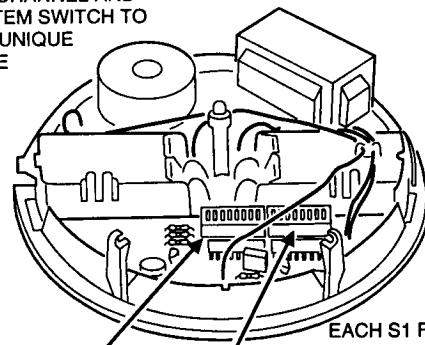

SYSTEM
SWITCH

CHANNEL
SWITCH

EACH S1 FORMAT
TRANSMITTER MUST
BE SET TO A
DIFFERENT CODE

Figure 25. ESL371 Transmitter Coding Switch

MODE SWITCH
SWITCH #1 OPEN (STATUS)
SWITCH #2 OPEN (RESTORE)
SWITCH #3 CLOSED (NO DELAY)
SWITCH #4 OPEN FOR N/C LOOP
SWITCH #4 CLOSED FOR N/O LOOP

CHANNEL
SWITCH

SET CHANNEL AND
SYSTEM SWITCH TO
ANY UNIQUE CODE

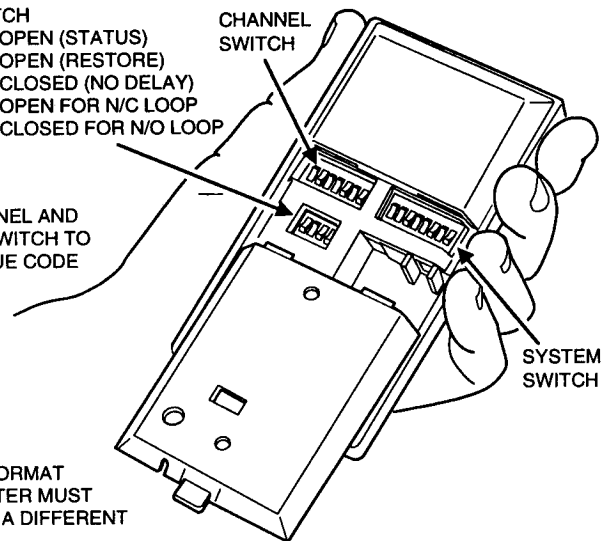

SYSTEM
SWITCH

EACH S1 FORMAT
TRANSMITTER MUST
BE SET TO A DIFFERENT
CODE

Figure 26. ST Transmitter Coding Switches

MOTION DETECTOR PROGRAMMING

When the CP-90 is in the autoinstall mode, each time a transmitter sends a signal the CP-90 installs it as a new sensor. Because PIR motion detectors trigger each time motion is detected, the CP-90 could install more than once for a single sensor. Therefore, **use the Manual Install RF Sensor mode (Function 002, explained in the next section) when installing PIR motion detectors.** Cover the PIR's lens after programming to prevent it from transmitting again until the installation is complete.

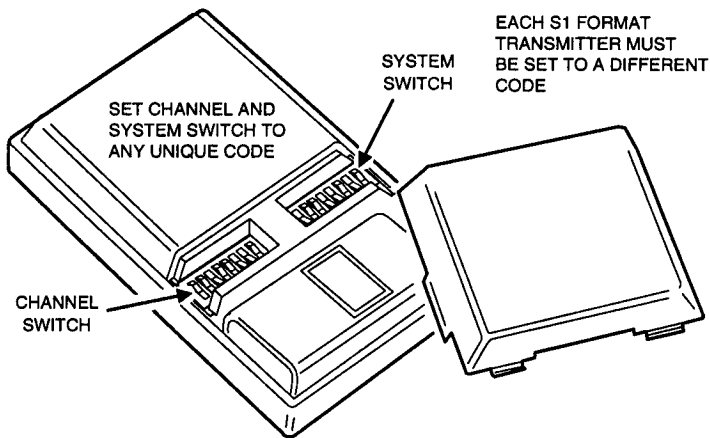

Figure 27. ST-1 Transmitter Coding Switches
(Not Tested by UL)

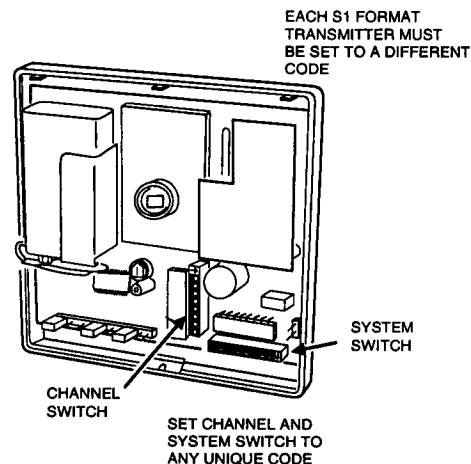

Figure 29. 50S40A Transmitter Coding
(NOTE: Not tested by UL for burglary requirements.)

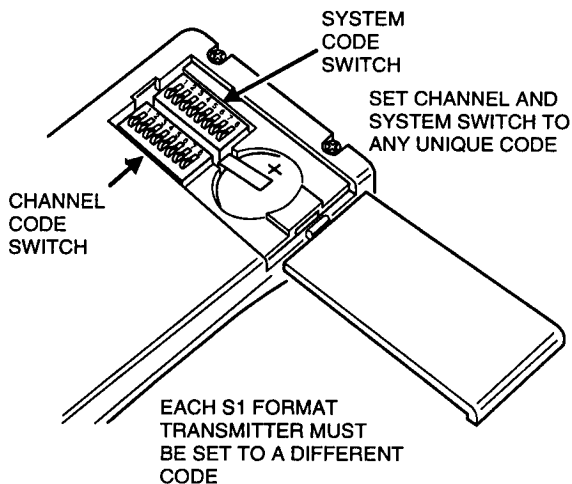

Figure 28. ST-23A Transmitter Coding Switches
(Not Tested by UL)

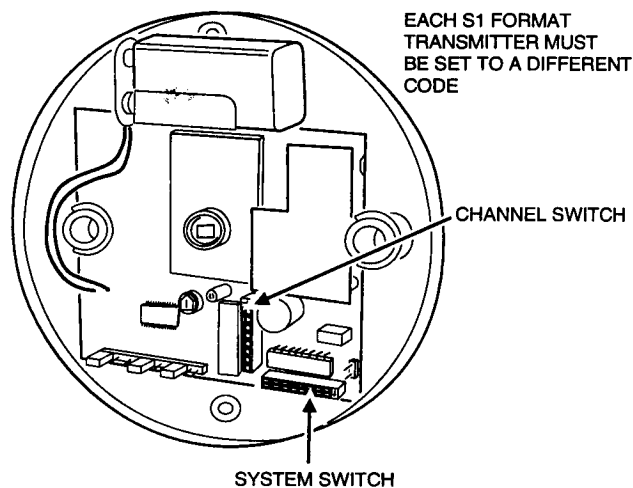

Figure 30. 70S60 Transmitter Coding Switches
(NOTE: Not tested by UL for burglary requirements.)

PROGRAM DESCRIPTIONS

In the following descriptions the Function, Selector and Value fields are notated as 000.000.000. If the description has no Value field (000.000) then no value needs to be entered. If the field can accept various Values (a range of Values) then the range is shown.

Pressing CLEAR (★) at any time during any program step terminates that step and sets the Function, Selector and Value fields to 0.

This section gives detailed descriptions of each CP-90 programming function. **Follow along using the CP-90 Programming Key sheet (P/N 207418). Installers familiar with this system should be able to program the system just using the CP-90 Programming Key sheet along with the CP-90 Programming Worksheet (P/N 207744).** Linear has provided all of the details for each of the functions here for advanced users and reference.

SENSOR INSTALLATION

Use the following functions to install sensors including hardwire loops.

★ **IMPORTANT: Before installing sensors make sure that the communicator reporting formats (Functions 050.002 & 050.003) and sensor reporting codes (Functions 070 & 075) are programmed to the desired values prior to installing sensors, so that the default reporting codes can be set correctly when zone assignments are made to the sensors.**

In the Autoinstall sensor mode, it is possible to learn the same sensor multiple times, with different sensor numbers. To avoid this, make sure that each sensor is tripped (or test button pressed) only once. Use the Manual Install RF Sensor (Function 002) for PIR motion detectors.

TK-90 Wireless Keypads

Wireless keypads are assigned two numbers, a sensor number (4-64) and an accessory number (65-72). After the keypad is learned, it always displays its accessory number, not its sensor number. **Press the ★ key to install the TK-90 when in Function 001 or 002.**

000.000 Display Installed Sensors

The displayed Value field is the number of sensors installed (including hardwire loops). Pressing STORE starts the display scrolling through each installed sensor number. Pressing STORE stops the display and returns the display to the Value field.

001.000 Auto-Install RF Sensors
Automatically installs RF sensors and RF control stations at the next available sensor number. **Prior to using this step make sure that Function 050.002 and 050.003 have been set to the correct reporting formats and any report codes that are not the same as the factory defaults have been programmed.**

Press CYCLE twice to display the Value field. See Figure 31. The Value field shows the number of sensors currently installed. Press STORE. A high-low tone will sound, indicating that the system is ready to accept a transmission. After the sensor transmission is received, the display will show the sensor number sequentially assigned by the CP-90 to that sensor. The display will continue to show the last sensor number learned. Each time a sensor transmission is received the accept tones will sound to signal the installer that a transmitter was entered.

Supervisory and tamper transmissions are not learned; only test or violation (open) signals trigger the learning activity. Pressing STORE terminates the auto-install and displays the Function field again.

⚠ **IMPORTANT: The CP-90 will learn the same transmitter more than once if multiple transmissions are received. Also, do not trigger portable transmitters for longer than one second while auto-installing.**

002.000 Manually Install RF Sensor
[Selector range 4-64]

Installs an RF sensor or RF control station at a particular sensor number (Selector 4-64 = sensor 4-64). See Figure 32. Press CYCLE, enter the sensor number you want into the Selector field and press CYCLE again. If that number is free (no sensor already installed there) then the display will advance to the Value field and display the number of installed sensors. Pressing STORE will place the CP-90 into sensor learn mode. A high-low tone will sound, indicating that the system is ready to accept a transmission. After a sensor is learned the accept tones will sound and the display will show the sensor number. Pressing STORE during learn mode (before a transmission is received) or after a sensor is learned returns the display to the Function field. If, during Selector field entry, a selected sensor number is already assigned, the rejection tones will sound and the display *will not* advance to the Value field. Supervisory and tamper transmissions are not learned; only test or violation (open) signals can be learned.

003.000 Manually Remove RF Sensor
[Selector range 4-64]

Removes an RF sensor from the system. Enter the desired sensor (Selector 4-64 = sensor 4-64) into the Selector field and press CYCLE, the display will show the total number of sensors installed. To remove the sensor press STORE. If a sensor was installed at that number then the accept tones will sound and the display will return to the Function field. If the selected sensor does not exist (or it's a wireless keypad) then the rejection tones will sound and the display remains on the Value field. **Use the accessory delete (Function 023.000) to delete wireless (TK-90) keypads using the accessory number.**

**ENTERING TRANSMITTERS IN AUTO-INSTALL MODE
(FUNCTION 001)**

**START
HERE**

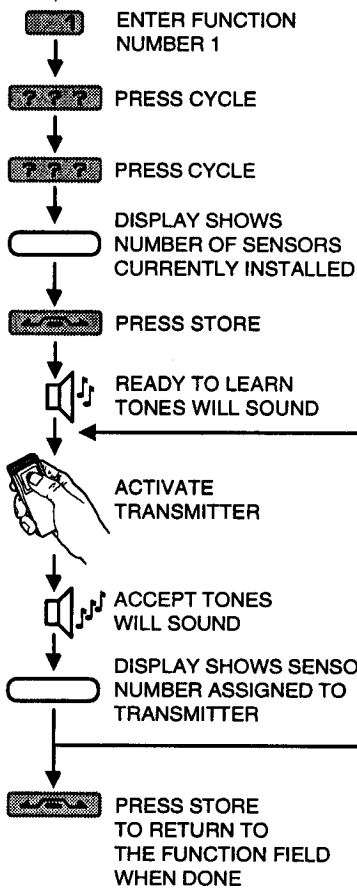

Figure 31. Entering Transmitters in Auto-install Mode

**ENTERING A TRANSMITTER IN MANUAL INSTALL MODE
(FUNCTION 002)**

**START
HERE**

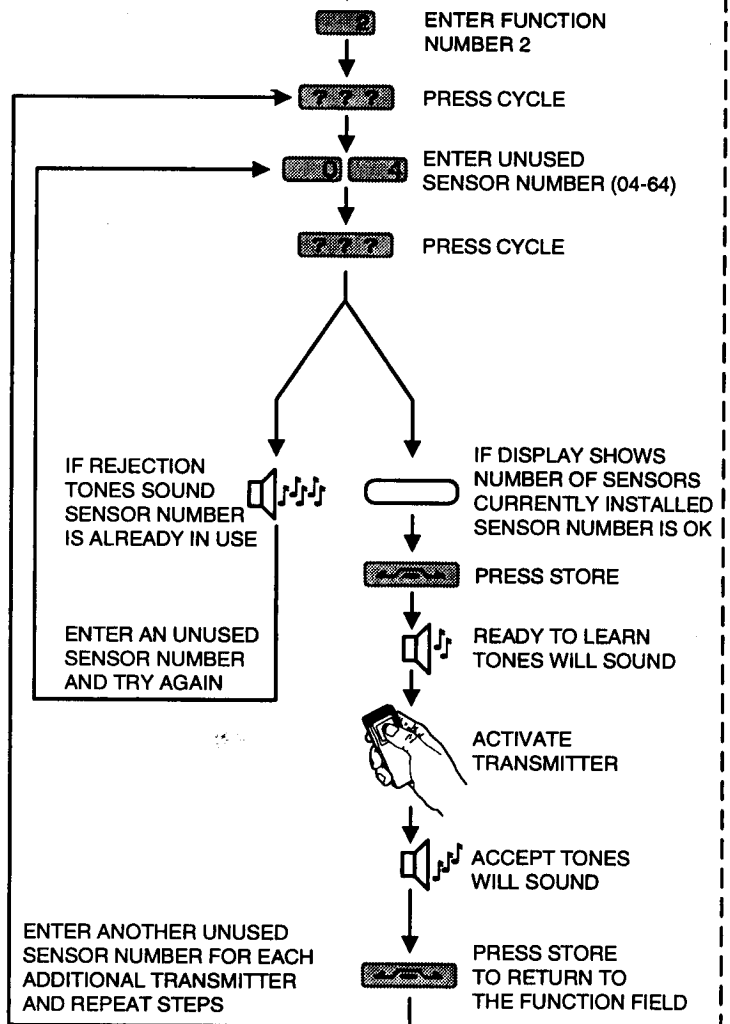

Figure 32. Entering Transmitters in Manual Install Mode

NOTE: For each of the following functions, unless otherwise stated, pressing the STORE key causes the new Value to be stored into the CP-90's memory and the display will return to the Function field. If the command is accepted, the accept tones will sound.

004.000.000 **Sensor Zone Type**
[Selector range 1-64] **[Value range 0-16, default = 0]**
 Assigns a zone type to a hardwired loop or RF sensor. See Figure 33. The Selector field specifies which sensor or loop to use (Selector 1-64 = sensor 1-64) and the Value field specifies the zone type. 17 different zone types are provided; a detailed description of each zone type can be found in the System Zones section of this manual. The Value numbers are shown in the Sensor Zone Table on the next page. If the specified sensor does not exist or the Value is out of range, the rejection tones will sound and the display remains on the Selector field. Use Function 017 to assign zone types to keys on TX type handheld remote transmitters.

NOTE: Changing the sensor zone type will replace its reporting code with the default reporting code for the new zone type.

005.000.000 **Sensor Entry Delay**
[Selector range 1-64] **[Value range 0-3, default = 0]**
 Selector 1-64 = sensor 1-64. Makes sensors delayed or instant. For exterior sensors, Default Value of 0 makes the sensor instant, a Value of 1 gives the sensor entry delay time #1 specified by Function 120.001, and a Value of 2 gives the sensor entry delay time #2 specified by programming Function 120.002.

A Value of 3 is for interior followers, **do not enter a Value of 3 for exterior sensors** (the sensor will act as an instant sensor).

For interior sensors, Default Value of 0 makes the sensor instant (alarms during entry and exit delays), a Value of 1 gives the sensor entry delay time #1 specified by Function 120.001, and a Value of 2 gives the sensor entry delay time #2 specified by programming Function 120.002.

A Value of 3 is for interior followers, this causes the sensor to be delayed during exit delays and entry delays, but instant if it is triggered first.

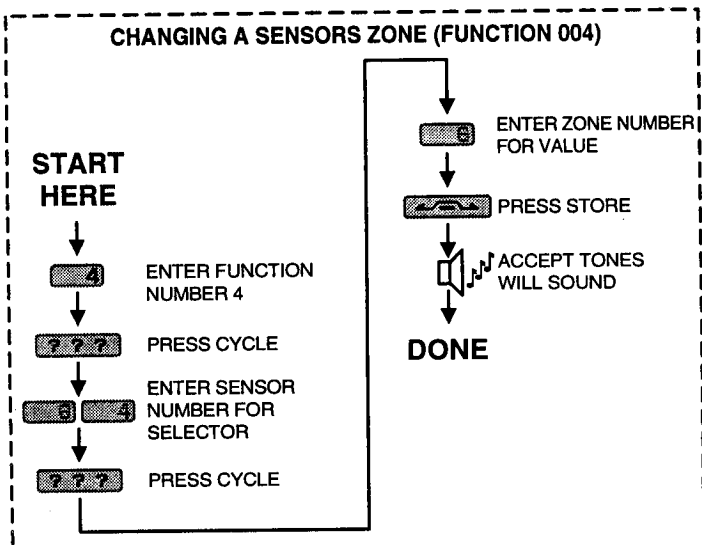

Figure 33. Example of Entering Sensor Zone Type

006.000.000 **RF Sensor Type**
[Selector range 4-64] **[Value range 0-1, default = 0]**
 Selector 4-64 = sensor 4-64. Makes the selected sensor a non-restoring type such as a PIR, panic button or glass break detector. Default Value of 0 specifies a restoring sensor such as a door or window. Enter a Value of 1 to specify a non-restoring sensor. MegaCode format and TX series portable transmitters are automatically set up as non-restoring sensors when they are installed with Functions 001 or 002.

007.000.000 **RF Sensor Supervision**
[Selector range 4-64] **[Value range 0-1, default = 0]**
 Selector 4-64 = sensor 4-64. Enables or disables sensor supervision. Default Value of 0 is for supervised. Enter a Value of 1 for unsupervised. Sensors should be supervised unless they can be taken out of range of the receiver. MegaCode format portable transmitters are automatically set up as unsupervised sensors when they are installed with Functions 001 or 002.

008.000.000 **Sensor Local Alarm**
[Selector range 1-64] **[Value range 0-1, default = 0]**
 Selector 1-64 = sensor 1-64. Makes the selected sensor report audible or silent alarms. Default Value of 0 sets the sensor for audible alarms. Enter a Value of 1 for silent alarms. Sensors programmed for silent alarms *will not sound entry delay beeps* or activate the pre-alarm or alarm outputs on the control output connector. **Silent sensors will still trigger the violation output.**

009.000.000 **Sensor Bypassing**
[Selector range 1-64] **[Value range 0-1, default = 0]**
 Selector 1-64 = sensor 1-64. Allows a sensor to be bypassed or not. Default Value of 0 allows the selected sensor to be bypassed. Enter a Value of 1 to disable bypassing.

010.000.000 **Sensor Audio Report**
[Selector range 1-64] **[Value range 0-2, default = 0]**
 Allows a sensor to trigger central station audio reporting. If the optional two-way audio feature is installed and an alarm is caused by one of these sensors, on completion of the central station report, the system will enter an audio mode as specified by this Value. Default Value of 0 selects no audio response. Enter Value of 1 to select listen in audio only and a Value of 2 to select two-way audio. **2-way audio does not trigger with non-reporting sensors.**

SPECIAL KEYS USED DURING KD-90 LCD KEYPAD CAPTION PROGRAMMING (FUNCTION 016)

- = GO FOWARD TO NEXT CHARACTER OR WORD IN CAPTION TABLE
- = GO BACKWARD TO PREVIOUS CHARACTER OR WORD IN CAPTION TABLE
- = REPOSITION CURSOR TO THE START OF THE DISPLAY LINE
- = ADVANCE CURSOR TO THE NEXT POSITION OF THE DISPLAY LINE

NOTE: TO FILL THE REST OF THE DISPLAY LINE WITH BLANKS, USE # TO POSITION CURSOR, THEN ENTER A VALUE OF 255 AND PRESS STORE

Figure 34. Special Keys for KD-90 Caption Programming

SENSOR INSTALLATION TABLE					
FUNCTION	SELECTOR	VALUE	DEFAULT	DESCRIPTION	ACTION/VALUE
0	0			DISPLAY INSTALLED SENSOR	PRESS STATUS TWICE FOR TOTAL # OF SENSORS, THEN PRESS STORE, DISPLAY WILL SHOW ALL INSTALLED SENSOR #'S
1	0			AUTO-INSTALL RF SENSORS	PRESS STORE, TEST SENSOR TO INSTALL, ASSIGNS DEFAULTS TO SENSOR AND REPORT CODES ** WARNING ** SET COMMUNICATOR FORMAT BEFORE USING
2	4-64			MANUALLY INSTALL RF SENSOR	SET SELECTOR TO SENSOR #, TEST SENSOR TO INSTALL, ASSIGNS DEFAULTS TO SENSOR AND REPORT CODES ** WARNING ** SET COMM. FORMAT BEFORE USING
3	4-64			MANUALLY REMOVE RF SENSOR	SET SELECTOR TO SENSOR #, PRESS STORE TO DELETE SENSOR
4	1-64	0-16	0	SENSOR ZONE	USE ZONE TABLE TO CHOOSE ZONE TYPE #0-16, PRESS STORE TO ENTER
5	1-64	0-2	0	SENSOR ENTRANCE DELAY	0 = INSTANT 1 = DELAY ONE (SEE FUNCTION 120.001) 2 = DELAY TWO (SEE FUNCTION 120.002) 3 = INTERIOR FOLLOWER (SENSOR ZONE TYPES 1 & 2 ONLY)
6	4-64	0-1	0	SENSOR TYPE	0 = NORMAL OPEN/CLOSE SENSOR 1 = PIR OR NON-RESTORING SENSOR
7	4-64	0-1	0	SENSOR SUPERVISION	0 = SUPERVISED 1 = UNSUPERVISED
8	1-64	0-1	0	SENSOR LOCAL ALARM	0 = AUDIBLE 1 = SILENT
9	1-64	0-1	0	SENSOR BYPASSING	0 = CAN BE BYPASSED 1 = CANNOT BE BYPASSED
10	1-64	0-2	0	SENSOR AUDIO REPORTING	0 = NO SENSOR AUDIO 1 = LISTEN IN 2 = TWO-WAY AUDIO
11	0			HARDWIRE LOOP AUTO SETUP	PRESS STORE WHEN "00" IS DISPLAYED TO INSTALL ALL HARDWIRE LOOPS
12	1-3	1-100	4	HARDWIRE LOOP RESPONSE TIME	VALUE TIMES 100ms = LOOP RESPONSE TIME; SELECTOR 1-3 = LOOP 1-3
13	1-3	0-1	0	HARDWIRE LOOP SUPERVISION	0 = EOL RESISTOR SUPERVISED (2.2K); 1 = NO EOL RESISTOR
14	1-3	0-3	0	HARDWIRE LOOP TROUBLE TYPE	0 = NO TROUBLE 1 = TROUBLE ON OPEN 2 = TROUBLE ON SHORT 3 = TROUBLE ON OPEN OR SHORT
15	1-3	0-1	0	HARDWIRE LOOP DISABLE	0 = LOOP DISABLED 1 = LOOP ENABLED
16	1-64	0-255		KD-90 LCD CAPTIONS	ENTER SENSOR NAMES TO BE DISPLAYED ON KD-90 LCD KEYPAD
17	3-17	TOTAL # OF TX TYPE REMOTES		ZONE SELECT FOR TX-91, TX-92 & TX-94 REMOTE TRANSMITTERS	SET ZONE TYPE IN SELECTOR FIELD, PRESS DESIRED REMOTE BUTTON; REMOTE MUST HAVE BEEN ENTERED IN FUNCTIONS 001 OR 002

SENSOR ZONE TABLE		
VALUE	ZONE TYPE	DESCRIPTION
0	EXTERIOR	ARMED IN LEVELS 3, 4, 5 & 6 - CHIMES IN LEVEL 2
1	RESTRICTED INTERIOR	ARMED IN LEVELS 4, 5 & 6
2	INTERIOR	ARMED IN LEVEL 4 ONLY
3	FIRE	CONTINUOUSLY ARMED (24-HOUR FIRE ZONE)
4	EMERGENCY	CONTINUOUSLY ARMED (24-HOUR EMERGENCY ZONE)
5	POLICE/HOLD-UP	CONTINUOUSLY ARMED (24-HOUR POLICE/HOLDUP ZONE)
6	ARM/DISARM TOGGLE	SENSOR IS A PUSHBUTTON THAT ALTERNATELY ARMS TO LEVEL 4 AND LEVEL 1 (AUTOMATIC FORCED BYPASSING GOING TO LEVEL 4)
7	REMOTE PANIC/EMERGENCY	HOLDING FOR 3-SECONDS TRIGGERS 24-HOUR EMERGENCY ZONE
8	REMOTE PANIC/POLICE	HOLDING FOR 3-SECONDS TRIGGERS 24-HOUR POLICE ZONE
9	GUARD ZONE	ARMED IN LEVELS 1, 2, 3, 4, 5 & 6 - REPORTS AS BURGLAR IN LEVEL 4; ALSO SUITABLE FOR GLASS BREAK
10	ENVIRONMENTAL TYPE A	CONTINUOUSLY ARMED 24-HOUR ENVIRONMENTAL ZONE TRIGGERS ANNUNCIATE, VIOLATION & REPORTS
11	ENVIRONMENTAL TYPE B	CONTINUOUSLY ARMED 24-HOUR ENVIRONMENTAL ZONE TRIGGERS ANNUNCIATE, VIOLATION & NO REPORTS
12	ENVIRONMENTAL TYPE C	CONTINUOUSLY ARMED 24-HOUR ENVIRONMENTAL ZONE TRIGGERS ANNUNCIATE ONLY, NO VIOLATION & NO REPORTS
13	CHIME ONLY	ACTIVE IN LEVELS 1, 2 & 3 TRIGGERS CHIME ONLY, NO VIOLATION, NO REPORTS
14	AUTOMATION #1	TRIGGERS AUTOMATION #1 OUTPUT ON CONTROL OUTPUT
15	AUTOMATION #2	TRIGGERS AUTOMATION #2 OUTPUT ON CONTROL OUTPUT
16	ACCESS ONLY	TRIGGERS ACCESS OUTPUT ON CONTROL OUTPUT
17	TX REMOTE BUTTON DISABLE	"DEAD" ZONE TO DISABLE DESIRED BUTTONS ON TX-92 & TX-94 REMOTE TRANSMITTERS

Figure 35. Sensor Installation & Zone Tables

011.000 **Hardwire Loop Auto Setup**
 Installs any connected hardwire loops into the CP-90 memory. **First, be sure all of the hardwire loops are wired correctly and their doors/windows are closed (contacts in restored state).** Enter 0 for Selector and Value fields, then press STORE to install the loops. The accept tones will sound when the loops are entered into memory. All loops will be installed; disable unused loops using Function 015 to remove them from sensor test displays.

012.000.000 **Hardwire Loop Response Time**
[Selector range 1-3] [Value range 1-100, default = 4]
 Selector 1-3 = loop 1-3. Sets the delay time before the loop will cause a violation. Default Value of 4 gives each loop 400 mS delay. The Value selected times 100 mS equals the loop delay. The shortest delay is 100 ms. The longest delay is 10 seconds. This delay is for loop stability with different types of sensors and is *not* to be used for an entry delay.

013.000.000 **Hardwire Loop Supervision**
[Selector range 1-3] [Value range 0-1, default = 0]
 Selector 1-3 = sensor/loop 1-3. Allows setting up non-supervised hardwire loops (loops without end-of-line (EOL) resistor termination). The default Value of 0 sets loops for a 2.2K EOL resistor. Enter a Value of 1 for non-EOL loops.

014.000.000 **Hardwire Loop Trouble Type**
[Selector range 1-3] [Value range 0-3, default = 0]
 Selector 1-3 = sensor/loop 1-3. Selects the loop condition that will cause a supervisory trouble report. The default Value of 0 sets loops for no trouble reporting. Enter a Value of 1 for trouble when the loop is open (N/O loop with EOL resistor); 2 for trouble when loop is shorted (N/C loop with EOL resistor); 3 for trouble when loop is opened or shorted (trouble only loop with EOL resistor).

015.000.000 **Hardwire Loop Disable**
[Selector range 1-3] [Value range 0-1, default = 0]
 Selector 1-3 = sensor/loop 1-3. All three hardwire loops are enabled when Function 011 is used. Any unused loops that weren't connected when Function 011 was used would be recognized as normally open loops. These unused loops can be disabled so that they won't show up when testing sensors in Level 8. **Enter a Value of 0 for any unused hardwire loops.**

016.000.000 **KD-90 LCD Keypad Captions**
[Selector range 1-64] [Value range 0-255]
 Selector 1-64 = sensor 1-64. Refer to the table on the next page and Figure 34 to select words that describe each sensor's location or function. Use a KD-90 keypad to program this step. Enter the word number as the Value for each sensor. **More than one Value can be entered for each sensor for multiple word entries.** Press STORE after each Value number is entered. Up to 24 characters total can be entered. As each Value is entered, the word with a blank space after it will appear on the bottom line of the KD-90 display. Single characters do not have a blank space after them.

Use the # key to forward space the display cursor. Use the EMERGENCY key to move the cursor to position one. Enter 255 as a Value to erase all characters to the right of the cursor. To erase the entire line, press EMERGENCY, then 255, then STORE.

017.000 **TX Type Transmitter Zone Select**
[Selector range 3-17]

Sets the zones that each button on a TX-91, TX-92 or TX-94 portable transmitter will trigger. The Value numbers are shown in the Sensor Zone Table. Set the zone type value number in the Selector field, press CYCLE (Value displays the total # of TX units) then STORE. After pressing STORE, a high-low tone will sound, indicating that the system is ready to accept a transmission. Press the desired transmitter button. As each key is accepted, the keypad will display the sensor # of the TX transmitter and the accept tones will sound (see Figure 36). More than one transmitter may be installed using one Function 017 operation. **The TX transmitter must have already been entered with Function 001 or 002 before this step will work. All buttons are disabled (sensor zone 17) on TX type transmitters when first installed.**

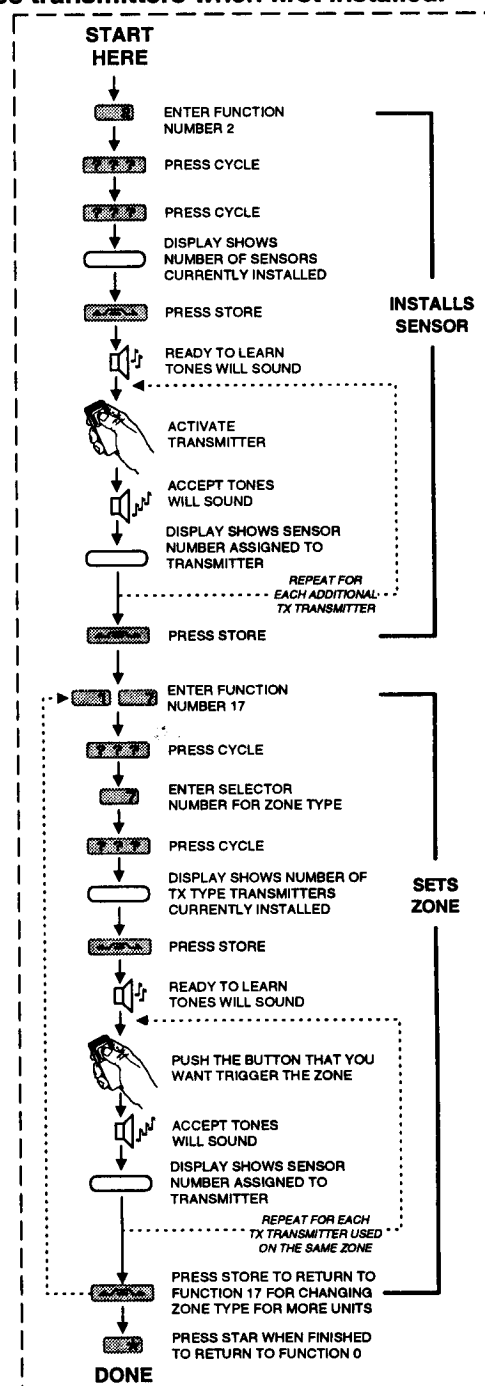

Figure 36. Example of Entering a TX Type Transmitter

KD-90 LCD KEYPAD ENGLISH CAPTION VALUES

VALUE	DISPLAYED WORD (CAPTION)	VALUE	DISPLAYED WORD (CAPTION)	VALUE	DISPLAYED WORD (CAPTION)	VALUE	DISPLAYED WORD (CAPTION)
0	0	64	#	128	Garage	192	Pump
1	1	65	&	129	Gas	193	Quarters
2	2	66	'	130	Gate	194	Ramp
3	3	67	(131	Glass	195	Rear
4	4	68)	132	Guest	196	Receiving
5	5	69	*	133	Gun	197	Recreation
6	6	70	+	134	Hallway	198	Relay
7	7	71	,	135	Heat	199	Remote
8	8	72	-	136	Hobby	200	Restroom
9	9	73	.	137	Hold	201	RF
10	ONE BLANK SPACE	74	/	138	Hold-up	202	Right
11	a	75	=	139	House	203	Roof
12	b	76	Access	140	Ice	204	Room
13	c	77	Alarm	141	Infrared	205	Safe
14	d	78	Area	142	Inside	206	Screen
15	e	79	Arm	143	Interior	207	Second
16	f	80	Attic	144	Intrusion	208	Security
17	g	81	Audio	145	Janitor	209	Sensor
18	h	82	Auxiliary	146	Key	210	Shipping
19	i	83	Back	147	Keypad	211	Shock
20	j	84	Basement	148	Keyswitch	212	Shop
21	k	85	Bathroom	149	Kitchen	213	Shutter
22	l	86	Beam	150	Laundry	214	Side
23	m	87	Bedroom	151	Left	215	Silent
24	n	88	Breakfast	152	Level	216	Silver
25	o	89	Button	153	Library	217	Skylight
26	p	90	Cabinet	154	Lift	218	Sliding
27	q	91	Carpport	155	Light	219	Smoke
28	r	92	Ceiling	156	Liquor	220	South
29	s	93	Chime	157	Living	221	Spa
30	t	94	Closet	158	Loading	222	Sprinkler
31	u	95	Computer	159	Lobby	223	Stairs
32	v	96	Control	160	Locker	224	Station
33	w	97	Den	161	Loft	225	Steam
34	x	98	Detector	162	Lower	226	Stereo
35	y	99	Dining	163	Main	227	Stock
36	z	100	Dock	164	Maintenance	228	Storage
37	A	101	Door	165	Master	229	Study
38	B	102	Downstairs	166	Mat	230	Sump
39	C	103	Drawer	167	Medical	231	System
40	D	104	Dressing	168	Microwave	232	Tamper
41	E	105	Driveway	169	Middle	233	Temperature
42	F	106	East	170	Monitor	234	Third
43	G	107	Electric	171	Motion	235	Tool
44	H	108	Elevator	172	Mud	236	Transmitter
45	I	109	Emergency	173	North	237	Trap
46	J	110	Employee	174	Nursery	238	Ultrasonic
47	K	111	Entrance	175	Office	239	Upper
48	L	112	Exercise	176	On/Off	240	Upstairs
49	M	113	Exit	177	Outside	241	Utility
50	N	114	Exterior	178	Overhead	242	Valve
51	O	115	Factory	179	Panic	243	Vault
52	P	116	Family	180	Parking	244	Vibration
53	Q	117	Fire	181	Passive	245	Video
54	R	118	First	182	Patio	246	Violation
55	S	119	Floor	183	Perimeter	247	Wall
56	T	120	Flow	184	Photo	248	Warehouse
57	U	121	Fluid	185	PIR	249	Water
58	V	122	Foil	186	Play	250	West
59	W	123	Foyer	187	Plant	251	Window
60	X	124	Freezer	188	Police	252	Yard
61	Y	125	Front	189	Pool	253	Zone
62	Z	126	Fumace	190	Power	254	NULL (NOTHING)
63	I	127	Game	191	Proximity	255	ERASE ENTIRE LINE

Figure 37. KD-90 LCD Captions

ACCESSORY (Keypad) INSTALLATION

Use the following functions to install accessories such as Control Stations (keypads). Only Functions 023 & 024 affect TK-90 wireless keypads (installed by Function 001 or 002).

020.000 Display Accessories

The Value field displays the number of accessories recognized as being wired to the CP-90, but not necessarily installed yet. Even though the CP-90 recognizes connected keypads, they must be *installed* using Function 021. Pressing STORE starts the display scrolling through each accessory number. Pressing STORE stops the display and returns the display to the Value field. Accessories are numbered 65 through 72.

021.000 Install Connected Accessories

The Value field displays the number of installed accessories. Pressing the STORE key permanently installs all connected accessories. You must use this function after connecting any control station or other accessory to store the accessory's identification number in memory. **Always use this step after initial installation and after connecting a new accessory, even if the accessory appears to be responding normally.**

023.000 Remove Installed Accessory

[Selector range 65-72]

Selector 65-72 = keypad 65-72. The Value field will display the accessory number (65-72) of the controlling keypad. Use this step to determine the accessory number of a keypad if it is not known. Pressing the STORE key causes the accessory specified by the Selector field to be deleted from the system. The rejection tones will sound if the selected accessory does not exist, or if an attempt is made to delete the controlling keypad (you can't delete the keypad you are using to program the system). Uninstalled accessories must be installed (Function 021) before they can be removed with this function.

024.000.000 Keypad Emergency Keys

[Selector range 65-72]

[Value range 0-7, default = 7]

Selector 65-72 = keypad 65-72. Each keypad can have its three emergency keys independently enabled or disabled. Use the Keypad Emergency Key Table on the next page to choose a Value corresponding to the desired option. Keypad stickers are provided to cover the unused buttons.

025.000.000 Standby Display Intensity

[Selector range 65-72]

[Value range 0-3, default = 0]

Selector 65-72 = keypad 65-72. The standby lighting intensity is set by this Value. Control Station display lighting is turned on when someone presses a key or during entry/exit delays (Functions 029 & 030). The display remains on for a period of 45 seconds after the last keystroke, then the display goes into standby mode. Default Value of 0 is for off. Enter 1 for low, 2 for medium, 3 for high. Set to 1, 2 or 3 if you want the Security Level displayed on K-90 keypads at all times.

026.000.000 Standby Downlight Intensity

[selector range 65-72]

[Value range 0-3, default = 0]

Selector 65-72 = keypad 65-72. The standby lighting intensity is set by this Value. Control Station downlights are turned on when someone presses a key or during entry/exit delays (Functions 029 & 030). The downlights remain on for a period of 45 seconds after the last keystroke, then the downlights go into standby mode. Default Value of 0 is for off. Enter 1 for low, 2 for medium, 3 for high.

027.000.000

[Selector range 65-72]

Active Display Intensity

[Value range 0-3, default = 2]

Selector 65-72 = keypad 65-72. The active display intensity is set by this Value. Control Station displays are made active when someone presses a key or during entry/exit delays (Functions 029 & 030). Default Value of 2 is for medium. Enter 1 for low, 3 for high. **A Value of 0 is not recommended for K-90 keypads.**

028.000.000

[Selector range 65-72]

Active Downlight Intensity

[Value range 0-3, default = 2]

Selector 65-72 = keypad 65-72. The active downlight intensity is set by this Value. Control Station downlights are made active when someone presses a key or during entry/exit delays (Functions 029 & 030). Default Value of 2 is for medium. Enter 1 for low, 3 for high.

029.000.000

[Selector range 65-72]

Lights During Entry Delay

[Value range 0-1, default = 1]

Selector 65-72 = keypad 65-72. Default Value of 1 causes the selected keypad's display and downlights to be set to the programmed active intensity during entry delays. Enter a Value of 0 to cause lights to be off during the entry delay.

030.000.000

[Selector range 65-72]

Lights During Exit Delay

[Value range 0-1, default = 1]

Selector 65-72 = keypad 65-72. Default Value of 1 causes the selected keypad's display and downlights to be set to the programmed active intensity during exit delays. Enter a Value of 0 to cause lights to be off during the exit delay.

031.000.000

[Selector range 65-72]

Keystroke Beep Loudness

[Value range 0-3, default = 2]

Selector 65-72 = keypad 65-72. Each keypad can be individually set for keystroke beep loudness. When a keypad key is pressed, a beep is made to provide the operator with audible feedback. Default Value of 2 is for medium. Enter 0 for off, 1 for low, 3 for high.

032.000.000

[Selector range 65-72]

Annunciation Loudness

[Value range 0-3, default = 2]

Selector 65-72 = keypad 65-72. System annunciation tone loudness can be individually set for each selected keypad. Default Value of 2 is for medium. Enter 0 for off, 1 for low, 3 for high.

033.000.000

[Selector range 65-72]

Alarm Tone Loudness

[Value range 0-3, default = 2]

Selector 65-72 = keypad 65-72. System alarm tone loudness can be individually set for each selected keypad. Default Value of 2 is for medium. Enter 0 for off, 1 for low, 3 for high.

034.000.000

[Selector range 65-72]

Emergency Key Audio

[Value range 0-2, default = 0]

Selector 65-72 = keypad 65-72. If the optional two-way audio feature is installed, and an alarm is caused by one of the keypad emergency keys, then, on completion of the central station report, the system will enter an audio mode as specified by this value. Default Value of 0 selects no audio response. Enter 1 to select listen in audio only and 2 selects two-way audio.

035.000.000

[Selector range 65-72]

KD-90 LCD Keypad Captions

[Value range 0-255]

Selector 65-72 = keypad 65-72. Refer to the table in Figure 37 on the previous page to select words that describe each keypads location. Use a KD-90 keypad to program this step.

To program the captions, follow the instructions for Function 016.

ACCESSORY INSTALLATION TABLE					
FUNCTION	SELECTOR	VALUE	DEFAULT	DESCRIPTION	ACTION/VALUE
20	0			DISPLAY ACCESSORIES	PRESS STORE, DISPLAY WILL SHOW ALL ACCESSORIES IN MEMORY
21	0			AUTOINSTALL ACCESSORIES	PRESS STORE, CONNECTED ACCESSORIES ARE PERMANENTLY INSTALLED
23	65-72			MANUALLY REMOVE ACCESSORY	SET SELECTOR TO ACCESSORY #, PRESS STORE TO REMOVE FROM MEMORY
24	65-72	0-7	7	KEYPAD EMERGENCY KEYS ENABLE	USE KEYPAD EMERGENCY KEY TABLE TO CHOOSE DESIRED OPTION. ENTER VALUE 0-7
25	65-72	0-3	0	STANDBY DISPLAY INTENSITY	0 = OFF (STANDBY DEFAULT) 1 = LOW 2 = MEDIUM (ACTIVE DEFAULT) 3 = HIGH
26	65-72	0-3	0	STANDBY DOWNLIGHT INTENSITY	
27	65-72	0-3	2	ACTIVE DISPLAY INTENSITY	
28	65-72	0-3	2	ACTIVE DOWNLIGHT INTENSITY	
29	65-72	0-1	1	KEYPAD LIGHTS DURING ENTRY DELAY	0 = LIGHTS OFF DURING ENTRY DELAY 1 = LIGHTS ON DURING ENTRY DELAY
30	65-72	0-1	1	KEYPAD LIGHTS DURING EXIT DELAY	0 = LIGHTS OFF DURING EXIT DELAY 1 = LIGHTS ON DURING EXIT DELAY
31	65-72	0-3	2	KEYPAD KEYSTROKE BEEP LOUDNESS	0 = OFF/SILENT 1 = LOW 2 = MEDIUM 3 = HIGH
32	65-72	0-3	2	KEYPAD SYSTEM ANNUNCIATION TONE LOUDNESS	
33	65-72	0-3	2	KEYPAD ALARM TONE LOUDNESS	
34	65-72	0-2	0	KEYPAD EMERGENCY KEY AUDIO RESPONSE	0 = NO AUDIO 1 = LISTEN IN 2 = TWO WAY AUDIO
35	65-72	0-250		KD-90 LCD CAPTIONS	ENTER VALUE NUMBERS FROM LCD CAPTION TABLE FOR ACCESSORY NAMES TO BE DISPLAYED ON KD-90 LCD KEYPAD

KEYPAD EMERGENCY KEY TABLE			
VALUE	OPTION	VALUE	OPTION
0	DISABLE ALL THREE EMERGENCY KEYS	4	FIRE KEY ACTIVE ONLY
1	POLICE KEY ACTIVE ONLY	5	FIRE & POLICE KEYS ACTIVE
2	EMERGENCY KEY ACTIVE ONLY	6	FIRE & EMERGENCY KEYS ACTIVE
3	EMERGENCY & POLICE KEYS ACTIVE	7	ENABLE ALL THREE EMERGENCY KEYS

Figure 38. Accessory Installation & Emergency Key Tables

GENERAL COMMUNICATOR OPERATION

Use the following Functions and Selectors to change Values for general communicator operation. Refer to the table in Figure 40. The default values already in memory should be correct for most applications.

NOTE: For each of the following functions, unless otherwise stated, pressing the STORE key causes the new value to be stored into the CP-90's memory and the display will return to the Function field. If the command is accepted, the accept tones will sound.

050.001.000 Communicator On/Off
[Value range 0-1, default = 0]

Enables or disables the CP-90's built-in digital communicator. Default Value of 0 is for a local alarm system. Enter a Value of 1 to enable the communicator to report to one or more central stations. **This Value must be set to 1 if the system is to be monitored. Do not set this Value to 1 until all other programming is completed.**

NOTE: When re-entering Programming Level 9 to make program adjustments, set this Value to 0 first to disable the communicator during programming.

050.002.000 Communication Format 1
[Value range 0-13, default = 5]

Selects the first central station communications format. All telephone numbers programmed can select either communications format 1 or 2 (see Functions 061.001, 061.002 & 061.003). Enter a Value matching the desired format from the Communicator Format Table on the next page.

NOTE: Executing this function also installs the default sensor report codes and report code options for the selected format (see Figures 45 & 47).

050.003.000 Communication Format 2
[Value range 0-13, default = 5]

Selects the second central station communications format. All telephone numbers programmed can select either communications format 1 or 2 (see Functions 061.001, 061.002 & 061.003). Enter a Value matching the desired format from the Communicator Format Table on the next page.

NOTE: Executing this function also installs the default sensor report codes and report code options for the selected format (see Figures 45 & 47).

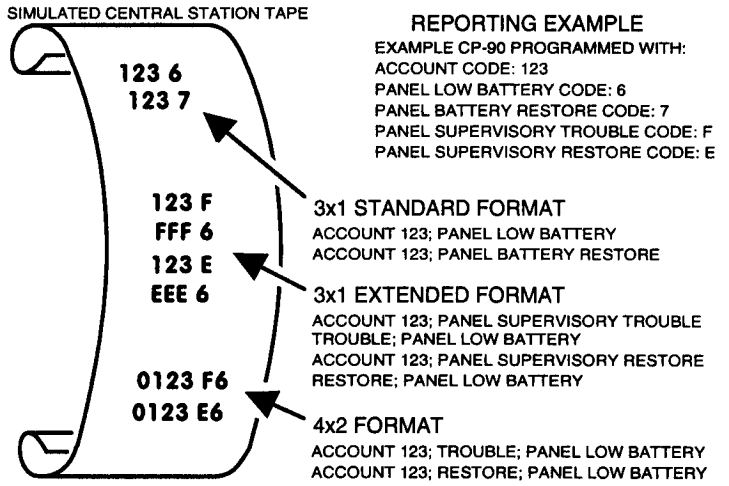

Figure 39. Reporting Code Examples for Different Formats

050.004.000 Dialing Format
[Value range 0-1, default = 0]

Selects how the telephone will be dialed. Default Value of 0 is for tone (DTMF) dialing (be sure the phone system supports tone dialing). Enter a Value of 1 for pulse (rotary) dialing.

Opening & Closing Report Option Overview

The CP-90 can report openings and closings a variety of ways. The system defaults program the system for a closing report each time the system is armed and an opening report each time the system is disarmed.

Opening reports can be programmed to occur only after an alarm (exception reporting) with Function 050.005.

Closing reports can be programmed to occur only after an the system is armed with one or more sensors bypassed (exception reporting) with Function 050.006.

To disable all opening and closing reports for standard formats, program Functions 070 & 075, Selectors 014, 015 & 034 to 0.

To disable all opening and closing reports for SuperSpeed format, program Functions 074 & 079, Selectors 001, 002 & 003 to 0.

To disable all opening and closing reports for SIA format, program Functions 072 & 077, Selectors 001, 002 & 003 to 0.

To disable all alarm cancel reports (disarming during an alarm), program Functions 070 & 075, Selector 16 to 0.

050.005.000 Opening Reports by Exception
[Value range 0-1, default = 0]

Selects whether opening reports will be sent each time the system is disarmed or only after an alarm has occurred. This is helpful in commercial accounts so that the central station knows when the subscriber has arrived on-site to check the cause of the alarm. Default Value of 0 is for standard opening reports. Enter a Value of 1 for opening reports only after an alarm.

050.006.000 Closing Reports by Exception
[Value range 0-1, default = 0]

Selects whether closing reports will be sent each time the system is armed or only after the system is armed with bypassed sensors. This is helpful in commercial and residential accounts so that the central station knows when the subscriber has partially armed the system without complete protection. Bypassed sensors are reported with extended reporting formats. Default Value of 0 is for standard closing reports. Enter a Value of 1 for closing reports only after sensors have been bypassed.

050.007.000 Tamper Report Routing
[Value range 0-1, default = 0]

Tamper reports normally use the supervisory call routing path (Function 060.006) to send their messages to the central station. By setting this Value to 1, tamper reports will use the alarm call routing path (Function 060.001).

050.008.000 Dialing Start Delay
[Value range 0-250, default = 0]

The Value number entered equals the number of seconds of delay after an alarm before the communicator will start dialing out. This setting allows time for the subscriber to disarm the system after accidentally triggering the alarm before it dials out. Don't set this value too long, because actual alarm reports caused by real intruders will also be delayed. Enter a Value in seconds if a dialing delay is required.

GENERAL COMMUNICATOR OPERATION					
FUNCTION	SELECTOR	VALUE	DEFAULT	DESCRIPTION	ACTION/VALUE
50	1	0-1	0	COMMUNICATOR ON/OFF	0 = LOCAL ALARM OPERATION ONLY 1 = DIGITAL COMMUNICATOR SENDS CENTRAL STATION REPORTS
50	2	0-13	5	COMMUNICATIONS FORMAT #1	USE COMMUNICATOR FORMAT TABLE TO CHOOSE DESIRED FORMAT, ENTER VALUE 0-13
50	3	0-13	5	COMMUNICATIONS FORMAT #2	
50	4	0-1	0	DIALING FORMAT	0 = DTMF (TONE) DIALING; 1 = PULSE DIALING
50	5	0-1	0	OPENING REPORTS BY EXCEPTION	0 = NORMAL OPENING REPORTS 1 = OPENING REPORTS ONLY WHEN DISARMING AFTER AN ALARM
50	6	0-1	0	CLOSING REPORTS BY EXCEPTION	0 = NORMAL CLOSING REPORTS 1 = CLOSING REPORTS ONLY WHEN FORCE ARMING
50	7	0-1	0	TAMPER REPORTING	0 = TAMPERS REPORT ON SUPERVISORY ROUTING 1 = TAMPERS REPORT ON ALARM ROUTING
50	8	0-250	0	DIALING START DELAY	ENTER NUMBER OF SECONDS FOR DELAY AS VALUE
50	9	1-250	2	DIALING ATTEMPTS BEFORE ROUTING CHANGE	ENTER NUMBER OF UNSUCCESSFUL ATTEMPTS TO CONNECT BEFORE ALTERNATE CALL ROUTING IS TRIED
50	10	1-250	2	DIALING ATTEMPTS BEFORE SLEEP CYCLE (ALL LINES)	ENTER NUMBER OF UNSUCCESSFUL ROUTING CHANGES BEFORE SLEEP CYCLE
50	11	0-250	2	NUMBER OF SLEEP CYCLES ALLOWED	ENTER NUMBER OF SLEEP CYCLES MADE BEFORE COMMUNICATIONS FAILURE
50	12	0-250	10	SLEEP CYCLE TIME	ENTER NUMBER OF MINUTES TO SLEEP BEFORE ATTEMPTING NEXT DIALING CYCLE
50	13	1-250	40	ANTI-JAM TIME	ENTER NUMBER OF SECONDS TO REMAIN ON-HOOK AFTER FAILURE TO DETECT DIAL TONE
50	14	0-250	0	AUTOMATIC TEST REPORT DELAY	ENTER NUMBER OF HOURS FROM PRESENT TIME UNTIL FIRST TEST REPORT IS SENT
50	15	0-10	0	SWINGER ELIMINATOR COUNT	0 = ALL VIOLATIONS REPORTED 1-10 = THE NUMBER OF REPORTED VIOLATIONS ANY SENSOR/LOOP CAN HAVE IN ONE ARM/DISARM CYCLE
50	16	0-1	1	REMOTE PROGRAMMING LOCKOUT	0 = NO REMOTE PROGRAMMING 1 = REMOTE PROGRAMMING ALLOWED
50	17	20-50	20	INVALID ACCESS TIMEOUT	TIME IN SECONDS TO DISCONNECT AFTER CP-90 ANSWERS FOR REMOTE PROGRAMMING AND COMMUNICATION IS NOT ESTABLISHED
50	18	0-7	1	AUTOMATIC TEST REPORT INTERVAL	0 = TEST REPORTS EVERY 12 HOURS 1-7 = TEST REPORTS EVERY 1-7 DAYS
50	19	0-1	0	INHIBIT SUPERSPEED END-OF-TX SIGNAL	0 = ETX AT END OF REPORT 1 = NO ETX SENT AT END OF REPORT
50	20	0-1	0	LISTEN-ONLY AUDIO AFTER DURESS PAC	0 = NO AUDIO AFTER DURESS PAC 1 = LISTEN-ONLY AUDIO AFTER DURESS PAC
51	1-6	000000-999999	987654	REMOTE PROGRAM ACCESS CODE	PASSWORD FOR REMOTE PROGRAMMING ACCESS, MUST BE PROGRAMMED IF VALUE FOR FUNCTION 050.016 IS 1

COMMUNICATOR FORMAT TABLE		
VALUE	FORMAT	FORMAT SPECIFICATIONS
0	10PPS 3x1 (ADEMCO STANDARD)	1400 Hz HANDSHAKE, 1900 Hz DATA
1	10PPS 3x1 TWO LINE EXTENDED	
2	10PPS 4x1	
3	10PPS 4x2 (SILENT KNIGHT)	2300 Hz HANDSHAKE, 1800 Hz DATA
4	20PPS 3x1 (SESCOA STANDARD)	
5	20PPS 3x1 TWO LINE EXTENDED	
6	20PPS 4x1	
7	20PPS 4x2	
8	40PPS 3x1	STANDARD RADIONICS FORMAT
9	40PPS 3x1 TWO LINE EXTENDED	
10	BFSK 3x2 (NOT TESTED FOR UL INSTALLATIONS)	SINGLE BLOCK
11	SIA (NOT TESTED FOR UL INSTALLATIONS)	2300 Hz HANDSHAKE, 1800 Hz DATA
12	SESCOA SUPERSPEED	PROPRIETARY
13	ADEMCO CONTACT ID (NOT TESTED FOR UL INSTALLATIONS)	

THE ABOVE UL DATA FORMATS WERE TESTED WITH THE SESCOA 3000C AND 3000R CENTRAL STATION RECEIVERS

Figure 40. General Communicator Operation Table

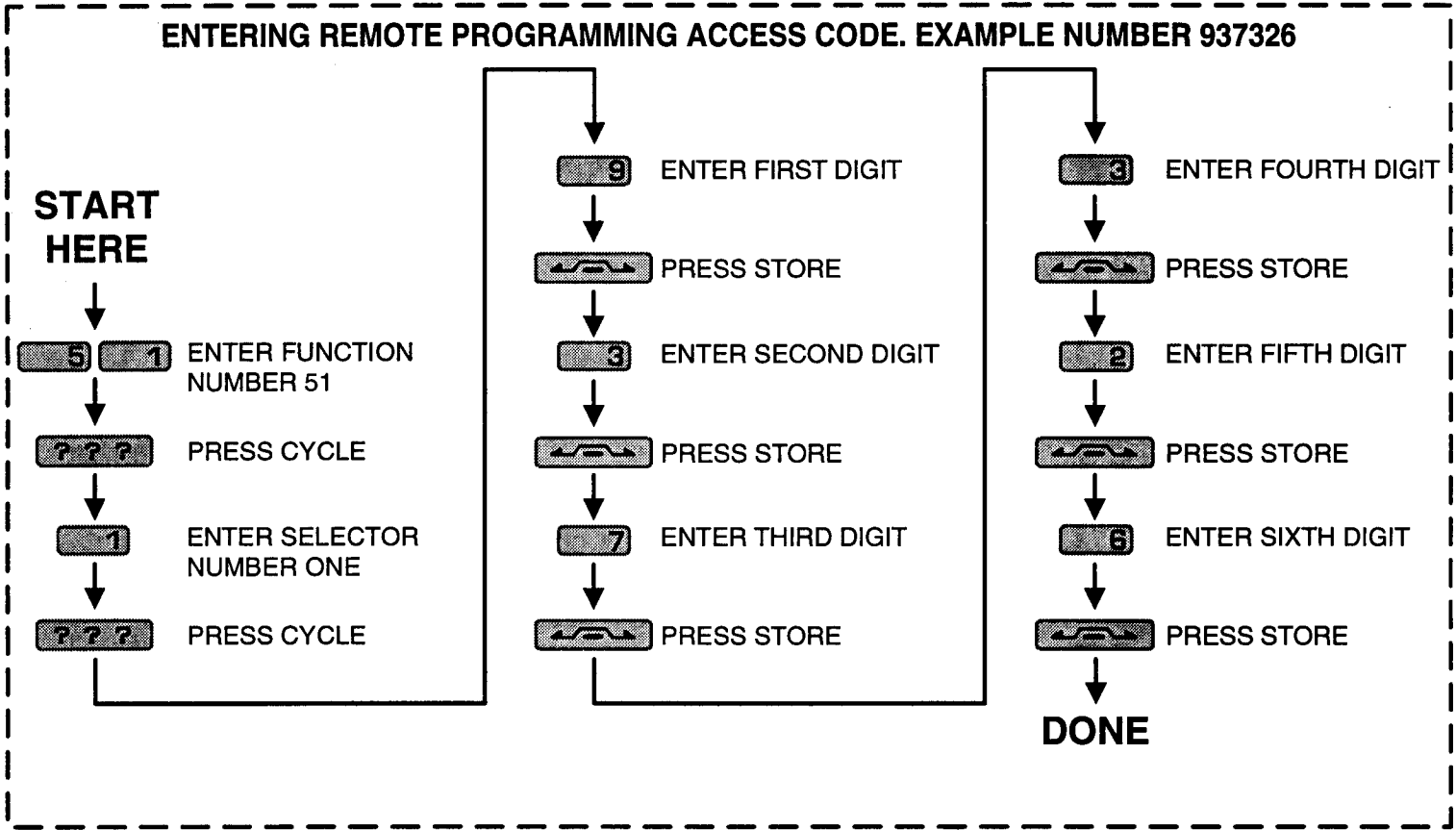

Figure 41. Example of Entering Remote Program Access Code

COMMUNICATOR ROUTING, TELEPHONE #'S & ACCOUNT #'S

Use the following Functions to set up the communicator telephone and account numbers and the way the calls are routed. Two copy steps (Functions 064 & 067) are provided to make it easier to duplicate the primary line information to the secondary and supervisory lines. See Figure 43 for example keystrokes for entering phone numbers. Also refer to the Table in Figure 42.

NOTE: For each of the following functions, unless otherwise stated, pressing the STORE key causes the new value to be stored into the CP-90's memory and the display will return to the Function field. If the command is accepted, the accept tones will sound.

060.001.000 Alarm Call Routing [Value range 0-3, default = 0]

This Value directs which telephone line(s) alarm calls and alarm cancels will go out on. Default Value of 0 is for primary line only. Enter 1 for primary then secondary if the primary fails, 2 for secondary then primary if the secondary fails and 3 for secondary only.

060.002.000 Open/Close Call Routing [Value range 0-6, default = 0]

This Value directs which telephone line(s) opening and closing calls will go out on. Default Value of 0 is for primary line only. Enter 1 for primary then secondary if the primary fails; 2 for secondary then primary if the secondary fails; 3 for secondary only; 4 for supervisory only; 5 for supervisory then primary if the supervisory fails; 6 for supervisory then secondary if the supervisory fails.

060.003.000 Restore Call Routing [Value range 0-6, default = 0]

This Value directs which telephone line(s) restore calls will go out on. Default Value of 0 is for primary line only. Enter 1 for primary then secondary if the primary fails; 2 for secondary then primary if the secondary fails; 3 for secondary only; 4 for supervisory only; 5 for supervisory then primary if the supervisory fails; 6 for supervisory then secondary if the supervisory fails.

060.004.000 Automatic/Manual Test Call Routing [Value range 0-6, default = 0]

This Value directs which telephone line(s) automatic and manual test calls will go out on. Default Value of 0 is for primary line only. Enter 1 for primary then secondary if the primary fails; 2 for secondary then primary if the secondary fails; 3 for secondary only; 4 for supervisory only; 5 for supervisory then primary if the supervisory fails; 6 for supervisory then secondary if the supervisory fails.

060.005.000 Audio Events Call Routing [Value range 0-6, default = 0]

This Value directs which telephone line(s) audio calls will go out on. Default Value of 0 is for primary line only. Enter 1 for primary then secondary if the primary fails; 2 for secondary then primary if the secondary fails; 3 for secondary only; 4 for supervisory only; 5 for supervisory then primary if the supervisory fails; 6 for supervisory then secondary if the supervisory fails.

060.006.000 Supervisory/Trouble Call Routing [Value range 0-6, default = 0]

This Value directs which telephone line(s) supervisory and trouble calls will go out on. Default Value of 0 is for primary line only. Enter 1 for primary then secondary if the primary fails; 2 for secondary then primary if the secondary fails; 3 for secondary only; 4 for supervisory only; 5 for supervisory then primary if the supervisory fails; 6 for supervisory then secondary if the supervisory fails.

061.001.000 Primary Line Format [Value range 1-2, default = 1]

Selects which communicator format the primary telephone number will use. The formats 1 & 2 are selected with Function 050.002 & 050.003. Default Value is 1 for format 1. Enter a Value of 2 for format 2.

061.002.000 Secondary Line Format [Value range 1-2, default = 1]

Selects which communicator format the secondary telephone number will use. The formats 1 & 2 are selected with Function 050.002 & 050.003. Default Value is 1 for format 1. Enter a Value of 2 for format 2.

061.003.000 Supervisory Line Format [Value range 1-2, default = 1]

Selects which communicator format the supervisory telephone number will use. The formats 1 & 2 are selected with Function 050.002 & 050.003. Default Value is 1 for format 1. Enter a Value of 2 for format 2.

COMMUNICATOR ROUTING, TELEPHONE #'S AND ACCOUNT #'S					
FUNCTION	SELECTOR	VALUE	DEFAULT	DESCRIPTION	ACTION/VALUE
60	1	0-3	0	ALARM CALL ROUTING	0 = PRIMARY LINE ONLY 1 = PRIMARY THEN SECONDARY 2 = SECONDARY THEN PRIMARY 3 = SECONDARY ONLY
60	2	0-6	0	OPEN/CLOSE CALL ROUTING	0 = PRIMARY LINE ONLY 1 = PRIMARY THEN SECONDARY 2 = SECONDARY THEN PRIMARY 3 = SECONDARY ONLY 4 = SUPERVISORY ONLY 5 = SUPERVISORY THEN PRIMARY 6 = SUPERVISORY THEN SECONDARY
60	3	0-6	0	RESTORE CALL ROUTING	
60	4	0-6	0	AUTOMATIC/MANUAL TEST CALL ROUTING	
60	5	0-6	0	AUDIO EVENTS CALL ROUTING	
60	6	0-6	0	SUPERVISORY/TROUBLE CALL ROUTING	
61	1	1-2	1	PRIMARY LINE FORMAT	
61	2	1-2	1	SECONDARY LINE FORMAT	
61	3	1-2	1	SUPERVISORY LINE FORMAT	
62	1-24	0-15		PRIMARY LINE TELEPHONE NUMBER	ENTER TELEPHONE NUMBER UP TO 24 DIGITS, END WITH A "15", SEE DIALING TABLE FOR SPECIAL DIALING CODES
63	1-6	SEE ACCT. # TABLE		PRIMARY LINE ACCOUNT NUMBER	ENTER UP TO A 6 -DIGIT ACCOUNT # FOR THIS TELEPHONE NUMBER, END WITH A "15", SEE ACCOUNT NUMBER TABLE
64				COPY PRIMARY SETUP TO SECONDARY	PRESS STORE TO COPY PRIMARY TELEPHONE & ACCOUNT NUMBERS TO THE SECONDARY LINE
65	1-24	0-15		SECONDARY LINE TELEPHONE NUMBER	ENTER TELEPHONE NUMBER UP TO 24 DIGITS, END WITH A "15", SEE DIALING TABLE FOR SPECIAL DIALING CODES
66	1-6	SEE ACCT. # TABLE		SECONDARY LINE ACCOUNT NUMBER	ENTER UP TO A 6 -DIGIT ACCOUNT # FOR THIS TELEPHONE NUMBER, END WITH A "15", SEE ACCOUNT NUMBER TABLE
67				COPY SECONDARY SETUP TO SUPERVISORY	PRESS STORE TO COPY SECONDARY TELEPHONE & ACCOUNT NUMBERS TO THE SUPERVISORY LINE
68	1-24	0-15		SUPERVISORY LINE TELEPHONE NUMBER	ENTER TELEPHONE NUMBER UP TO 24 DIGITS, END WITH A "15", SEE DIALING TABLE FOR SPECIAL DIALING CODES
69	1-6	SEE ACCT. # TABLE		SUPERVISORY LINE ACCOUNT NUMBER	ENTER UP TO A 6 -DIGIT ACCOUNT # FOR THIS TELEPHONE NUMBER, END WITH A "15", SEE ACCOUNT NUMBER TABLE

SPECIAL DIALING VALUES	
TELEPHONE NUMBER VALUE	DIALING RESULT
11	EQUAL TO TOUCH TONE "*"
12	EQUAL TO TOUCH TONE "#"
13	3-SECOND DIALING PAUSE
14	WAIT FOR DIAL TONE
15	END OF PHONE NUMBER, ALWAYS ENTER A "15" AT THE END OF EACH PHONE NUMBER, DISPLAY WILL RETURN TO FUNCTION FIELD
ACCOUNT NUMBER TABLE	
FORMAT USED	VALID ACCOUNT NUMBERS
3x1 OR 3x2	ENTER 3 DIGITS - 0-9 AND 10-15 (A-F)
4x1 OR 4x2	ENTER 4 DIGITS - 0-9 AND 10-15 (A-F)
SUPERSPEED	ENTER 4 DIGITS - 0000 TO 3374
BFSK	ENTER 4 DIGITS - 0 PLUS 3 ACCOUNT NUMBER DIGITS
SIA	ENTER 1 TO 6 DIGITS - 000000 TO 999999
ADEMCO CONTACT ID	ENTER 4 DIGITS - 0000 TO 9999
ALL	ALWAYS ENTER A "15" AT THE END OF THE ACCOUNT NUMBER

Figure 42. Communicator Routing, Phone Number and Account Number Tables

062.000 Primary Line Telephone Number
[Selector range 1-24]
 Programs the primary line telephone number. Up to 24 digits can be used. Start at Selector 1, enter digit, press STORE, enter next digit, press STORE, repeat (see Figure 43). **Always enter a 15 after the last digit to end the Values.** The display will return to the Function field after entering the 15.
Special Values are: 11 equals “*”; 12 equals “#”; 13 is a 3-second dialing pause; 14 is an additional wait for dial tone.

063.000 Primary Line Account Number
[Selector range 1-6]
 Enters the account number for the primary line. Up to 6 digits can be entered. Each communicator format requires different length account numbers. All digits of the account number must be entered. Refer to the Account Number Table for account number length. Start at Selector 1, enter digit, press STORE, enter next digit, press STORE, repeat (see Figure 44). **Always enter a 15 after the last digit of the account number.** The display will return to the Function field after entering the 15.

064.001 Copy Primary Setup to Secondary
 Copies the primary line telephone and account number information to the secondary line Functions 65 & 66. Advance display to Value field and press STORE to copy.

065.000 Secondary Line Telephone Number
[Selector range 1-24]
 Programs the secondary line telephone number. Up to 24 digits can be used. Start at Selector 1, enter digit, press STORE, enter next digit, press STORE, repeat (see Figure 43). **Always enter a 15 after the last digit to end the Values.** The display will return to the Function field after entering the 15.
Special Values are: 11 equals “*”; 12 equals “#”; 13 is a 3-second dialing pause; 14 is an additional wait for dial tone.

066.000 Secondary Line Account Number
[Selector range 1-6]
 Enters the account number for the secondary line. Up to 6 digits can be entered. Each communicator format requires different length account numbers. All digits of the account number must be entered. Refer to the Account Number Table on the previous page for account number length. Start at Selector 1, enter digit, press STORE, enter next digit, press STORE, repeat (see Figure 44). **Always enter a 15 after the last digit of the account number.** The display will return to the Function field after entering the 15.

067.001 Copy Secondary Setup to Supervisory
 Copies the secondary line telephone and account number information to the supervisory line Functions 65 & 66. Advance display to Value field and press STORE to copy.

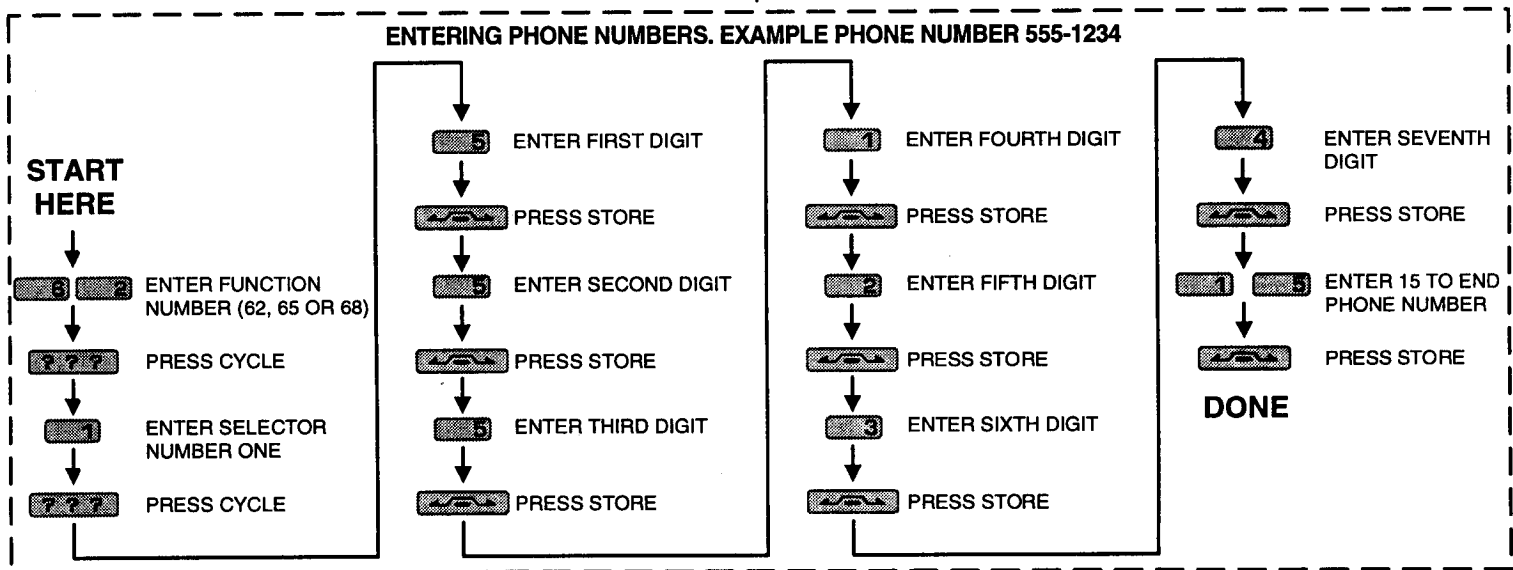

Figure 43. Example of Entering Phone Numbers

068.000 Supervisory Line Telephone Number

[Selector range 1-24]

Programs the supervisory line telephone number. Up to 24 digits can be used. Start at Selector 1, enter digit, press STORE, enter next digit, press STORE, repeat (see Figure 43). **Always enter a 15 after the last digit to end the Values.** The display will return to the Function field after entering the 15.

Special Values are: 11 equals “*”; 12 equals “#”; 13 is a 3-second dialing pause; 14 is an additional wait for dial tone.

069.000 Supervisory Line Account Number

[Selector range 1-6]

Enters the account number for the supervisory line. Up to 6 digits can be entered. Each communicator format requires different length account numbers. All digits of the account number must be entered. Refer to the Account Number Table for account number length. Start at Selector 1, enter digit, press STORE, enter next digit, press STORE, repeat (see Figure 44).

Always enter a 15 after the last digit of the account number. The display will return to the Function field after entering the 15.

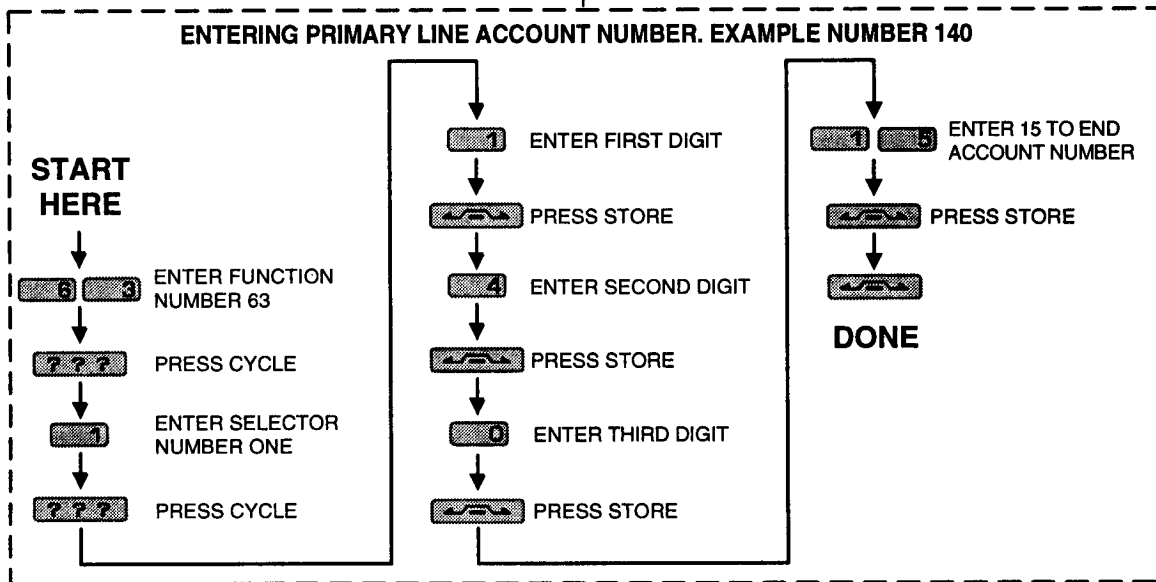

Figure 44. Example of Entering Account Numbers

REPORTING CODES FOR ALL FORMATS

EXCEPT SUPER SPEED & SIA

The following Functions and Selectors set the reporting codes for all of the communicator formats *except* SuperSpeed and SIA formats. The default values already in memory should be correct for most applications. Refer to the table in Figure 45. If the central station(s) that this system reports to require different codes, enter their Values for each format (#1 & #2). If only one format is being used, the format #2 settings need not be changed. **A Value of 0 disables that report.** Extended reporting formats will send the sensor number (1-15) after the report code.

Some formats will accept "hexadecimal" data (base 16 0-F). When entering hex Values, 10=A (sends 0), 11=B, 12=C, 13=D, 14=E, 15=F.

NOTE: Changing communicator formats with Functions 050.002 or 050.003 will install the default reporting codes. Select the format first, then change any reporting codes.

NOTE: For each of the following functions, unless otherwise stated, pressing the STORE key causes the new value to be stored into the CP-90's memory and the display will return to the Function field. If the command is accepted, the accept tones will sound.

Changing Report Codes Overview

Changing report codes for sensor violations (fire, intrusion, police, emergency and environmental) will **not** modify the report codes for sensors that have already been installed.

Reporting codes for sensors that have already been installed can be changed two ways:

1. Change the desired report codes with these Functions and then re-enter the effected sensor(s) zone type with Function 004. The sensor(s) will acquire the new report codes that have been set.
2. Use the sensor specific default report code override (Functions 071 & 076) to change the report code sensor by sensor. The sensor(s) zone type does not have to be re-entered.

Fire Sensor/Loop [Value range 0-15, default = 1]
070.001.000 for Format #1
075.001.000 for Format #2

Sets the reporting code for the fire loop or sensors programmed to the Fire Zone. Enter a new Value if a different reporting code than the default Value is required.

Exterior Intrusion [Value range 0-15, default = 3]
070.002.000 for Format #1
075.002.000 for Format #2

Sets the reporting code for the Exterior Zone sensors. Enter a new Value if a different reporting code than the default Value is required.

Interior Intrusion [Value range 0-15, default = 6]
070.003.000 for Format #1
075.003.000 for Format #2

Sets the reporting code for the Interior Zone sensors. Enter a new Value if a different reporting code than the default Value is required.

Police/Hold Up [Value range 0-15, default = 2]

070.004.000 for Format #1

075.004.000 for Format #2

Sets the reporting code for the Police/hold up Zone sensors. Enter a new Value if a different reporting code than the default Value is required.

Emergency [Value range 0-15, default = 4]

070.005.000 for Format #1

075.005.000 for Format #2

Sets the reporting code for the Emergency Zone sensors. Enter a new Value if a different reporting code than the default Value is required.

Environmental [Value range 0-15, default = 0]

070.006.000 for Format #1

075.006.000 for Format #2

Sets the reporting code for the Environmental Type "A" sensors. **This report is disabled by the default Value of 0.** Enter a new Value if this type of report is required.

Restore [Value range 0-15, default = 14(E)]

070.007.000 for Format #1

075.007.000 for Format #2

Sets the reporting code for sensor restoral. Enter a new Value if a different reporting code than the default Value is required.

Sensor Tamper [Value range 0-15, default = 0]

070.008.000 for Format #1

075.008.000 for Format #2

Sets the reporting code for sensor tampers. **This report is disabled by the default Value of 0.** Enter a new Value if this type of report is required.

Bypassed Sensor/Loop [Value range 0-15, default = 0]

070.009.000 for Format #1

075.009.000 for Format #2

Sets the reporting code for bypassed sensors and loops. **This report is disabled by the default Value of 0.** Enter a new Value if this type of report is required.

Keypad Fire [Value range 0-15, default = 1]

070.010.000 for Format #1

075.010.000 for Format #2

Sets the reporting code for the keypad fire button. Enter a new Value if a different reporting code than the default Value is required.

Keypad Police/Hold Up [Value range 0-15, default = 2]

070.011.000 for Format #1

075.011.000 for Format #2

Sets the reporting code for the keypad police/hold up button. Enter a new Value if a different reporting code than the default Value is required.

Keypad Emergency [Value range 0-15, default = 4]

070.012.000 for Format #1

075.012.000 for Format #2

Sets the reporting code for the keypad emergency button. Enter a new Value if a different reporting code than the default Value is required.

REPORTING CODES FOR ALL FORMATS EXCEPT SUPERSPEED, SIA & ADEMCO CONTACT ID						
FUNCTION		SELECTOR	VALUE	DEFAULT REPORT CODE	REPORT CODE DESCRIPTION	ACTION/VALUE ENTER NEW CODE IF DIFFERENT THAN DEFAULT (0 = NO REPORT)
FRMT #1	FRMT #2					
70	75	1	0-15	1	FIRE SENSOR/LOOP	EXTENDED SENSOR ID REPORT 1-15
70	75	2	0-15	3	EXTERIOR INTRUSION	
70	75	3	0-15	6	INTERIOR INTRUSION	
70	75	4	0-15	2	POLICE/HOLDUP	
70	75	5	0-15	4	EMERGENCY	
70	75	6	0-15	0	ENVIRONMENTAL	
70	75	7	0-15	14 (E)	RESTORE	
70	75	8	0-15	0	SENSOR TAMPER	
70	75	9	0-15	0	BYPASSED SENSOR/LOOP	
70	75	10	0-15	1	KEYPAD FIRE	
70	75	11	0-15	2	KEYPAD POLICE/HOLD-UP	EXTENDED ACCESSORY ID REPORT 1-8
70	75	12	0-15	4	KEYPAD EMERGENCY	
70	75	13	0-15	0	DURESS	
70	75	14	0-15	11 (B)	OPENING	EXTENDED PAC ID REPORTING 1-15
70	75	15	0-15	12 (C)	CLOSING	
70	75	16	0-15	13 (D)	CANCEL	
70	75	17	0-15	0	COMMUNICATOR AUTOMATIC TEST	
70	75	18	0-15	0	COMMUNICATOR MANUAL TEST	
70	75	19	0-15	0	CONTROL PANEL DOOR TAMPER	
70	75	20	0-15	0	KEYPAD TAMPER	
70	75	21	0-15	15 (F)	SUPERVISORY TROUBLE	EXTENDED SUPERVISORY TROUBLE REPORT CODE PREFIX
70	75	22	0-15	0	CONTROL PANEL LOW BATTERY	
70	75	23	0-15	0	CONTROL PANEL BATTERY RESTORE	
70	75	24	0-15	0	AC FAILURE	
70	75	25	0-15	0	AC RESTORE	
70	75	26	0-15	0	MEMORY ERROR	
70	75	27	0-15	0	AUXILIARY FUSE BLOWN	
70	75	28	0-15	0	FIRE POWER FUSE BLOWN	
70	75	29				
70	75	30	0-15	0	COMMUNICATION FAILURE	
70	75	31	0-15	0	KEYPAD TROUBLE	
70	75	32	0-15	0	SENSOR LOW BATTERY	EXTENDED SENSOR ID REPORT 1-15
70	75	33	0-15	0	SENSOR SUPERVISORY/TROUBLE	
70	75	34	0-15	12 (C)	FORCE CLOSE	EXTENDED PAC ID REPORT 1-15
70	75	35	0-15	0	SUPERVISORY RESTORE	EXTENDED SUPERVISORY RESTORAL REPORT CODE PREFIX
71	76	1-64	0-15		DEFAULT REPORT CODE OVERRIDE	ENTER DESIRED REPORT CODE FOR SPECIFIC SENSOR(S)

Figure 45. Reporting Codes for All Formats Except SuperSpeed, SIA and Ademco Contact ID

Duress [Value range 0-15, default = 0]

070.013.000 for Format #1

075.013.000 for Format #2

Sets the reporting code for the keypad duress code. **This report is disabled by the default Value of 0.** Enter a new Value if this type of report is required.

Opening [Value range 0-15, default = 11(B)]

070.014.000 for Format #1

075.014.000 for Format #2

Sets the reporting code for all opening reports. Enter a new Value if a different reporting code than the default Value is required.

Closing [Value range 0-15, default = 12(C)]

070.015.000 for Format #1

075.015.000 for Format #2

Sets the reporting code for normal closing reports. Enter a new Value if a different reporting code than the default Value is required.

NOTE: These Functions do not affect forced closing reports (see Function 034).

Cancel [Value range 0-15, default = 13(D)]

070.016.000 for Format #1

075.016.000 for Format #2

Sets the reporting code for alarm cancel. Enter a new Value if a different reporting code than the default Value is required.

NOTE: Alarm cancels use alarm routing.

Communicator Automatic Test

[Value range 0-15, default = 0]

070.017.000 for Format #1

075.017.000 for Format #2

Sets the reporting code for the automatic test reports. **This report is disabled by the default Value of 0.** Enter a new Value if this type of report is required.

NOTE: A reporting code must be entered in these selectors if automatic communicator tests are going to be used.

Communicator Manual Test

[Value range 0-15, default = 0]

070.018.000 for Format #1

075.018.000 for Format #2

These selectors set the reporting code for the Level 7 manual test reports. **This report is disabled by the default Value of 0.** Enter a new Value if this type of report is required.

NOTE: A reporting code must be entered in these selectors if manual communicator tests are going to be used.

Control Panel Door Tamper

[Value range 0-15, default = 0]

070.019.000 for Format #1

075.019.000 for Format #2

Sets the reporting code for control panel cabinet door tamper. **This report is disabled by the default Value of 0.** Enter a new Value if this type of report is required.

Keypad Tamper

[Value range 0-15, default = 0]

070.020.000 for Format #1

075.020.000 for Format #2

Sets the reporting code for keypad tamper. **This report is disabled by the default Value of 0.** Enter a new Value if this type of report is required.

Supervisory Trouble

[Value range 0-15, default = 15(F)]

070.021.000 for Format #1

075.021.000 for Format #2

Sets the reporting code for supervisory trouble events. Enter a new Value if a different reporting code than the default Value is required.

Control Panel Low Battery

[Value range 0-15, default = 0]

070.022.000 for Format #1

075.022.000 for Format #2

Sets the reporting code for control panel low battery. **This report is disabled by the default Value of 0.** Enter a new Value if this type of report is required.

Control Panel Battery Restore

[Value range 0-15, default = 0]

070.023.000 for Format #1

075.023.000 for Format #2

Sets the reporting code for control panel battery restore. **This report is disabled by the default Value of 0.** Enter a new Value if this type of report is required.

AC Failure

[Value range 0-15, default = 0]

070.024.000 for Format #1

075.024.000 for Format #2

Sets the reporting code for AC power failure. **This report is disabled by the default Value of 0.** Enter a new Value if this type of report is required.

AC Restore

[Value range 0-15, default = 0]

070.025.000 for Format #1

075.025.000 for Format #2

Sets the reporting code for AC power restoration. **This report is disabled by the default Value of 0.** Enter a new Value if this type of report is required.

Memory Error [Value range 0-15, default = 0]

070.026.000 for Format #1

075.026.000 for Format #2

Sets the reporting code for system memory error. **This report is disabled by the default Value of 0.** Enter a new Value if this type of report is required.

Auxiliary Fuse Blown [Value range 0-15, default = 0]

070.027.000 for Format #1

075.027.000 for Format #2

Sets the reporting code for blown auxiliary power fuse. **This report is disabled by the default Value of 0.** Enter a new Value if this type of report is required.

Fire Fuse Blown [Value range 0-15, default = 0]

070.028.000 for Format #1

075.028.000 for Format #2

Sets the reporting code for blown fire power fuse. **This report is disabled by the default Value of 0.** Enter a new Value if this type of report is required.

Communication Failure [Value range 0-15, default = 0]

070.030.000 for Format #1

075.030.000 for Format #2

Sets the reporting code for failed communications after all attempts. **This report is disabled by the default Value of 0.** Enter a new Value if this type of report is required.

Keypad Trouble [Value range 0-15, default = 0]

070.031.000 for Format #1

075.031.000 for Format #2

Sets the reporting code for supervisory trouble from a keypad. **This report is disabled by the default Value of 0.** Enter a new Value if this type of report is required.

Sensor Low Battery [Value range 0-15, default = 0]

070.032.000 for Format #1

075.032.000 for Format #2

Sets the reporting code for low battery from a wireless sensor. **This report is disabled by the default Value of 0.** Enter a new Value if this type of report is required.

Sensor Supervisory Trouble [Value range 0-15, default = 0]

070.033.000 for Format #1

075.033.000 for Format #2

Sets the reporting code for supervisory reports from a wireless sensor. **This report is disabled by the default Value of 0.** Enter a new Value if this type of report is required.

Force Close [Value range 0-15, default = 12(C)]

070.034.000 for Format #1

075.034.000 for Format #2

Sets the reporting code for arming the system with one or more bypassed sensors. Enter a new Value if a different reporting code than the default Value is required.

Supervisory Restore [Value range 0-15, default = 0]

070.035.000 for Format #1

075.035.000 for Format #2

Sets the reporting code for supervisory restoral events. Enter a new Value if a different reporting code than the default Value is required.

Default Report Code Override [Selector range 1-64] [Value range 0-15, default = 0]

071.000.000 for Format #1

076.000.000 for Format #2

These Selectors (1-64) set special reporting codes for each sensor/loop. Selectors 1-64 = sensors 1-64. The default Value of 0 allows the sensor to use the reporting code for the zone that it is programmed to. Enter a Value from 0 to 15 for any sensor that needs a special reporting code that's different from its zone reporting code.

SuperSpeed, SIA & Ademco CONTACT ID FORMAT

REPORTING OPTIONS

These selectors are only valid if SIA, SuperSpeed or Ademco Contact ID format has been selected as format #1 or #2 (Functions 050.002 & 050.003). Do not use these Functions if other formats have been selected. Use the following Functions and Selectors to enable and disable different SIA and SuperSpeed reporting options. Refer to the table in Figure 47.

NOTE: Changing communicator formats with Functions 050.002 or 050.003 will install the default report codes. Select the format first, then change any report codes.

Opening [Value range 0-1, default = 1]
072.001.000 For Format #1 SIA & Ademco Format #2 077.001.000
074.001.000 For Format #2 SuperSpeed Format #2 079.001.000

Default Value of 1 enables opening reports. Enter Value of 0 to disable opening reports.

Closing [Value range 0-1, default = 1]
072.002.000 For Format #1 SIA & Ademco Format #2 077.002.000
074.002.000 For Format #2 SuperSpeed Format #2 079.002.000

Default Value of 1 enables closing reports. Enter Value of 0 to disable closing reports (normal arming only).

Force Arm [Value range 0-1, default = 1]
072.003.000 For Format #1 SIA & Ademco Format #2 077.003.000
074.003.000 For Format #2 SuperSpeed Format #2 079.003.000

Default Value of 1 enables force arming and bypassed sensor reports. Enter Value of 0 to disable force arming reports.

Automatic Test [Value range 0-1, default = 0]
072.004.000 For Format #1 SIA & Ademco Format #2 077.004.000
074.004.000 For Format #2 SuperSpeed Format #2 079.004.000

Default Value of 0 disables automatic communicator test reports. Enter Value of 1 to enable automatic communicator test reports.

Manual Test [Value range 0-1, default = 1]
072.005.000 For Format #1 SIA & Ademco Format #2 077.005.000
074.005.000 For Format #2 SuperSpeed Format #2 079.005.000

Default Value of 1 enables manual communicator test reports. Enter Value of 0 to disable manual communicator test reports.

AC Failure [Value range 0-1, default = 1]
072.006.000 For Format #1 SIA & Ademco Format #2 077.006.000
074.006.000 For Format #2 SuperSpeed Format #2 079.006.000

Default Value of 1 enables AC failure reports. Enter Value of 0 to disable AC failure reports.

AC Restore [Value range 0-1, default = 1]
072.007.000 For Format #1 SIA & Ademco Format #2 077.007.000
074.007.000 For Format #2 SuperSpeed Format #2 079.007.000

Default Value of 1 enables AC restoral reports. Enter Value of 0 to disable AC restoral reports.

Control Panel Low Battery [Value range 0-1, default = 1]

072.008.000 For Format #1 SIA & Ademco Format #2 077.008.000
074.008.000 For Format #2 SuperSpeed Format #2 079.008.000

Default Value of 1 enables control panel low battery reports. Enter Value of 0 to disable control panel low battery reports.

Control Panel Battery Restore [Value range 0-1, default = 1]

072.009.000 For Format #1 SIA & Ademco Format #2 077.009.000
074.009.000 For Format #2 SuperSpeed Format #2 079.009.000

Default Value of 1 enables control panel battery restore reports. Enter Value of 0 to disable control panel battery restore reports.

Sensor/Loop Restore [Value range 0-1, default = 1]

072.010.000 For Format #1 SIA & Ademco Format #2 077.010.000
074.010.000 For Format #2 SuperSpeed Format #2 079.010.000

Default Value of 1 enables sensor/loop restoral reports. Enter Value of 0 to disable sensor/loop restoral reports.

Sensor/Loop Tamper [Value range 0-1, default = 1]

072.011.000 For Format #1 SIA & Ademco Format #2 077.011.000
074.011.000 For Format #2 SuperSpeed Format #2 079.011.000

Default Value of 1 enables sensor/loop tamper reports. Enter Value of 0 to disable sensor/loop tamper reports.

Sensor/Loop Supervisory [Value range 0-1, default = 1]

072.012.000 For Format #1 SIA & Ademco Format #2 077.012.000
074.012.000 For Format #2 SuperSpeed Format #2 079.012.000

Default Value of 1 enables sensor/loop supervisory reports. Enter Value of 0 to disable sensor/loop supervisory reports.

Sensor Low Battery [Value range 0-1, default = 1]

072.013.000 For Format #1 SIA & Ademco Format #2 077.013.000
074.013.000 For Format #2 SuperSpeed Format #2 079.013.000

Default Value of 1 enables sensor low battery reports. Enter Value of 0 to disable sensor low battery reports.

Supervisory Trouble [Value range 0-1, default = 1]

072.014.000 For Format #1 SIA & Ademco Format #2 077.014.000
074.014.000 For Format #2 SuperSpeed Format #2 079.014.000

Default Value of 1 enables supervisory trouble reports. Enter Value of 0 to disable supervisory trouble reports.

SIA & Ademco Contact ID Default Report Code Override

073.000.000 For Format #1 SIA & Ademco Format #2 078.000.000
[selector range 1-64] [Value range 0-12, default = 0]

For SuperSpeed: Not Supported

Selectors 1-64 = sensors 1-64. These selectors set special reporting codes for each sensor/loop. The codes are shown in the Report Code Override Table on the next page. The default Value of 0 allows the sensor to use the reporting code for the zone that it is programmed to. Enter a Value for any sensor that needs a special reporting code. The message to the central station will have 2 characters for the type of alarm, followed by 2 digits for the sensor number.

SIA & SUPERSPEED FORMAT REPORTING OPTIONS								
FUNCTION FOR SIA & ADEMCO		FUNCTION FOR SUPER-SPEED		SELECTOR	VALUE	DEFAULT	REPORT DESCRIPTION	ACTION/VALUE
FRMT #1	FRMT #2	FRMT #1	FRMT #2					
72	77	74	79	1	0-1	1	OPENING	0 = NO REPORT 1 = REPORT
72	77	74	79	2	0-1	1	CLOSING	
72	77	74	79	3	0-1	1	FORCE ARM	
72	77	74	79	4	0-1	0	AUTOMATIC TEST	
72	77	74	79	5	0-1	1	MANUAL TEST	
72	77	74	79	6	0-1	1	AC FAILURE	
72	77	74	79	7	0-1	1	AC RESTORE	
72	77	74	79	8	0-1	1	CONTROL PANEL LOW BATTERY	
72	77	74	79	9	0-1	1	CONTROL PANEL BATTERY RESTORE	
72	77	74	79	10	0-1	1	SENSOR/LOOP RESTORE	
72	77	74	79	11	0-1	1	SENSOR/LOOP TAMPER	
72	77	74	79	12	0-1	1	SENSOR/LOOP SUPERVISORY	
72	77	74	79	13	0-1	1	SENSOR LOW BATTERY	
72	77	74	79	14	0-1	1	SUPERVISORY TROUBLE	
73	78			1-64	0-12		DEFAULT REPORT CODE OVERRIDE	USE SIA REPORT CODE TABLE TO SELECT CODE FOR SPECIFIC SENSOR

**NOTE: THE VALUES IN THIS TABLE ARE ONLY VALID IF SIA, SUPERSPEED OR ADEMCO CONTACT ID FORMATS ARE SELECTED
(SIA FORMAT HAS NOT BEEN TESTED BY UL FOR CENTRAL STATION REPORTING CAPABILITY)**

SIA REPORT CODE OVERRIDE TABLE					
OVERRIDE VALUE	REPORT CODE xx=SENSOR	DESCRIPTION (VALUE OF 0=DEFAULT)	OVERRIDE VALUE	REPORT CODE xx=SENSOR	DESCRIPTION (VALUE OF 0=DEFAULT)
1	BAxx	BURGLARY ALARM	7	PAxx	PANIC ALARM
2	FAxx	FIRE ALARM	8	SAxx	SPRINKLER ALARM
3	GAxx	GAS ALARM	9	TAxx	TAMPER ALARM
4	HAxx	HOLDUP ALARM (DURESS)	10	UAxx	UNTYPED ALARM
5	KAxx	HEAT ALARM	11	WAxx	WATER ALARM
6	MAxx	MEDICAL ALARM	12	ZAxx	FREEZE ALARM

ADEMCO CONTACT ID REPORT CODE OVERRIDE TABLE					
OVERRIDE VALUE	REPORT CODE xx=SENSOR	DESCRIPTION (VALUE OF 0=DEFAULT)	OVERRIDE VALUE	REPORT CODE xx=SENSOR	DESCRIPTION (VALUE OF 0=DEFAULT)
1	130 0xx	BURGLARY ALARM	7	123 0xx	PANIC ALARM (122 0xx IF SILENT)
2	110 0xx	FIRE ALARM	8	113 0xx	SPRINKLER ALARM
3	141 0xx	GAS ALARM	9	137 0xx	TAMPER ALARM
4	121 0xx	HOLDUP ALARM (DURESS)	10	140 0xx	24-HOUR NON-BURGLARY ALARM
5	147 0xx	HEAT ALARM	11	144 0xx	WATER ALARM
6	100 0xx	MEDICAL ALARM	12	148 0xx	FREEZE ALARM

Figure 46. SIA, SuperSpeed and Ademco Contact ID Format Options and Report Code Overrides

Reporting Codes for Extended Formats

The 3 x 1 and 4 x 2 extended reporting formats are limited to 16 different reporting codes for the 64 possible CP-90 sensors. The CP-90 uses a reporting code matrix (see the Table in Figure 47) to define which reporting code will be sent for a specific sensor.

Extended Format Examples

For example, a CP-90 with account number 123 has a sensor #41 programmed as exterior and it causes an alarm then restores.

See Figure 48 for a 3 x 1 extended format reporting example.

See Figure 49 for a 4 x 2 extended format reporting example.

REPORTING CODE SENSOR MATRIX FOR EXTENDED FORMATS				
REPORTING CODE SENT	SENSOR NUMBERS PROGRAMMED INTO CP-90			
0	64	16	32	48
1	1	17	33	49
2	2	18	34	50
3	3	19	35	51
4	4	20	36	52
5	5	21	37	53
6	6	22	38	54
7	7	23	39	55
8	8	24	40	56
9	9	25	41	57
A (0)	10	26	42	58
B	11	27	43	59
C	12	28	44	60
D	13	29	45	61
E	14	30	46	62
F	15	31	47	63

Figure 47. Reporting Code Sensor Matrix

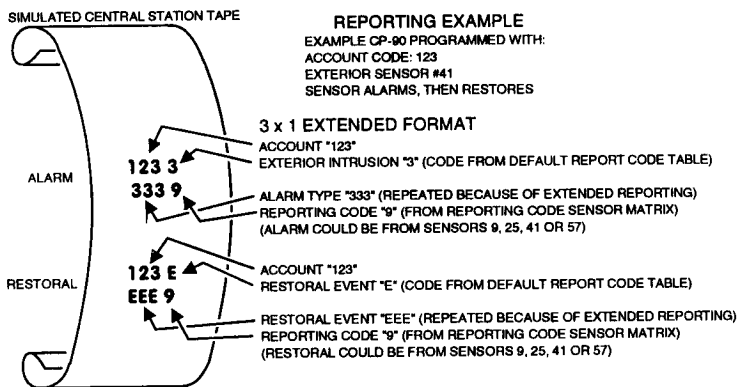

Figure 48. 3 x 1 Extended Format Reporting Example

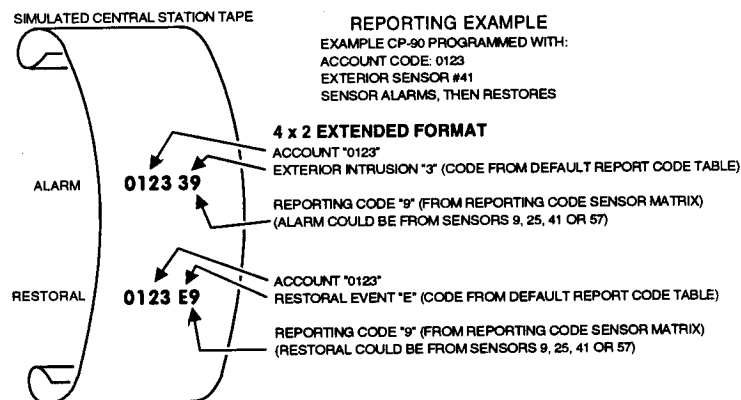

Figure 49. 4 x 2 Extended Format Reporting Example

SUPERSpeed, SIA & Ademco CONTACT ID FORMAT Reporting Codes

Refer to the Table in Figure 50 for details on central station reporting codes for SuperSpeed, SIA and Ademco Contact ID communicator formats.

These report codes are the default reporting code values. The report codes for SIA and Ademco Contact ID formats may be modified using the report code overrides (see Functions 073 and 078).

SUPERSPEED SENSOR & SUPERVISORY REPORTING CODES			
REPORTING CODE	REPORT DESCRIPTION xx = SENSOR/LOOP # ppp = PAC ID #	REPORTING CODE	REPORT DESCRIPTION xx = SENSOR/LOOP # ppp = PAC ID #
24H	AUTOMATIC COMMUNICATOR TEST	D77	PANEL RADIO FAILURE
Axx	ALARM	D79	PANEL TAMPER
A91	KEYPAD AND TX-TYPE TRANSMITTER FIRE	D82	FIRMWARE FAILURE
A92	KEYPAD TX-TYPE TRANSMITTER EMERGENCY	D85	EVENT LOG LIMIT REACHED
A93	KEYPAD TX-TYPE TRANSMITTER POLICE	D88	PANEL MEMORY ERROR
A94	KEYPAD BURG CAUSED BY LOCK-IN	DU	DURESS
AC	AC POWER FAILURE	Exx	RESTORE
CH	MANUAL COMMUNICATOR TEST	EAC	AC POWER RESTORE
Dxx	SUPERVISORY/TROUBLE	ELO	PANEL LOW BATTERY RESTORE
D73	COMMUNICATION FAILURE	IOP ppp	OPENING WITH PAC ID ppp
D75	AUXILIARY FUSE BLOWN	ICL ppp	CLOSING WITH PAC ID ppp
D76	FIRE POWER FUSE BLOWN	LO	PANEL LOW BATTERY

SIA SENSOR REPORTING CODES						
REPORT	ALARM xx = SENSOR/LOOP #	RESTORE xx = SENSOR/LOOP #	TAMPER xx = SENSOR/LOOP #	LOW BATTERY xx = SENSOR/LOOP #	SUPRVISORY xx = SENSOR/LOOP #	BYPASS xx = SENSOR/LOOP #
BURGLARY	BAxx	BRxx	TAxx	XTxx	BSxx	BBxx
FIRE	FAxx	FRxx	TAxx	XTxx	FSxx	FBxx
EMERGENCY	MAxx	MRxx	TAxx	XTxx	MSxx	MBxx
POLICE	PAxx	PRxx	TAxx	XTxx	PSxx	PBxx
ENVIRONMENT	UAxx	URxx	TAxx	XTxx	USxx	UBxx
TAMPER	TAxx	TRxx	TAxx	XTxx	TSxx	TBxx

SIA SUPERVISORY REPORTING CODES			
RPT CODE	REPORT DESCRIPTION xx = SENSOR/LOOP # pp = PAC ID #	RPT CODE	REPORT DESCRIPTION xx = SENSOR/LOOP # pp = PAC ID #
AR	AC RESTORE	TA79	PANEL TAMPER
AT	AC FAIL	UT75	AUXILIARY FUSE BLOWN
CFpp	FORCE ARM	UT77	RECEIVER RADIO FAILURE
CLpp	CLOSING	UT80	MEMORY ERROR
FT	FIRE FUSE BLOWN	UT85	EVENT LOG LIMIT
HAxx	DURESS	UTxx	KEYPAD TROUBLE
OPpp	OPENING	YC	COMMUNICATIONS FAILURE
ORpp	CANCEL	YR	PANEL BATTERY RESTORE
RP	AUTOMATIC TEST	YT	PANEL LOW BATTERY
RX	MANUAL TEST		

ADEMCO CONTACT ID SENSOR REPORTING CODES			
REPORTING CODE	REPORT DESCRIPTION (TRIGGERED BY ZONE) xx = SENSOR/LOOP # PREFIX 1 = VIOLATION PREFIX 3 = RESTORE	REPORTING CODE	REPORT DESCRIPTION (TRIGGERED BY ZONE) xx = SENSOR/LOOP # PREFIX 1 = VIOLATION PREFIX 3 = RESTORE
100 0xx	MEDICAL (EMERGENCY)	131 0xx	PERIMETER BURG (EXTERIOR)
110 0xx	FIRE (FIRE)	132 0xx	INTERIOR BURG (INTERIOR, RESTRICTED INTERIOR, KEYPAD BURG FROM LOCK-IN)
122 0xx	SILENT PANIC (POLICE/HOLD-UP)	133 0xx	24-HOUR BURG (GUARD ZONE)
123 0xx	AUDIBLE PANIC (POLICE/HOLD-UP)	140 0xx	24-HOUR NON-BURG (ENVIRONMENTAL A)

ADEMCO CONTACT ID OPEN/CLOSE REPORTING CODES			
REPORTING CODE	REPORT DESCRIPTION pp = PAC ID # PREFIX 1 = OPENING PREFIX 3 = CLOSING	REPORTING CODE	REPORT DESCRIPTION pp = PAC ID # PREFIX 1 = OPENING PREFIX 3 = CLOSING
401 0pp	NORMAL OPEN/CLOSE BY USER	408 000	QUICK ARM OR WIRELESS TOGGLE ARM
406 0pp	ALARM CANCEL (OPEN DURING ALARM) BY USER	409 000	REMOTE ARM FROM REMOTE ACCESS SOFTWARE
407 0pp	FORCED ARM (ARM WITH BYPASS) BY USER		

ADEMCO CONTACT ID SUPERVISORY REPORTING CODES			
REPORTING CODE	REPORT DESCRIPTION xx = SENSOR/LOOP # PREFIX 1 = NEW EVENT PREFIX 3 = RESTORE	REPORTING CODE	REPORT DESCRIPTION xx = SENSOR/LOOP # PREFIX 1 = NEW EVENT PREFIX 3 = RESTORE
301 000	PANEL AC FAILURE	380 085	EVENT LOG LIMIT REACHED
302 000	PANEL LOW BATTERY	380 088	PANEL MEMORY ERROR
380 0xx	TROUBLE (HARDWIRE LOOPS 1-3, KEYPADS 65-72)	381 0xx	SENSOR SUPERVISORY
380 000	PANEL FIRE FUSE BLOWN	383 0xx	KEYPAD OR SENSOR TAMPER
380 073	PANEL COMMUNICATION FAILURE	384 0xx	KEYPAD OR SENSOR LOW BATTERY
380 075	PANEL AUXILIARY FUSE BLOWN	570 0xx	SENSOR BYPASS
380 077	PANEL RADIO RECEIVER FAILURE	601 000	MANUAL TEST REPORT
380 079	PANEL TAMPER	602 000	AUTOMATIC 24-HOUR TEST REPORT

Figure 50. SuperSpeed, SIA & Ademco Contact ID Format Reporting Codes

PERSONAL ACCESS CODE (PAC) INSTALLATION

Personal Access Codes (2 to 5 digits) are used to authorize different levels of system control. There are 32 different codes numbered 1 - 32 with number 1 assigned as a temporary PAC. Various levels of control authorization can be programmed for each PAC. PAC ID's (1 - 32) are reported to the Central Station with Opening/Closing reports, if the format allows. **PAC's can be changed by the installer or by the user without entering system programming level (Level 9). See next page.**

The factory defaults are PAC's 1-31 empty, PAC number 32 set to 98765 with Level 9 programming privilege. Refer to the Table in Figure 52.

NOTE: In each of the following steps pressing the STORE key causes the new Value to be assigned to the selected PAC code and the display returns to the Function field. If the command is accepted, the accept tones will sound.

090.000 Personal Access Code Entry

[Selector range 2-32]

Selector 2-32 = PAC 2-32. To enter a PAC, first select Function 090, press CYCLE and enter which PAC you want to create or change (2-32). Press CYCLE again and then start entering the new PAC, 2 to 5 digits. Then press the STORE key to accept the new value and the display returns to the Function field (see Figure 51 for example). The rejection tones will sound if two few or too many digits are entered. If you make a mistake, repeat the entire sequence. For security, PAC's are never displayed once entered.

091.000 Cancel a PAC

[Selector range 2-32]

Selector 2-32 = PAC 2-32. To cancel a PAC, select which PAC to delete and press STORE. The old PAC will be deleted and the accept tones will sound. When cancelling a PAC, all characteristics of that PAC will be canceled as well.

092.000.000 High Security Level Limit

[Selector range 2-32] [Value range 0-9, default = 8]

Selector 2-32 = PAC 2-32. Sets the highest security level that a PAC may select. If "Quick Arming" (see Function 121.012) is enabled, it can override this setting. Value must be set to 9 if entry into system level programming (Level 9) is desired.

NOTE: PAC codes with Level 9 access cannot be changed outside of Level 9.

093.000.000 Low Security Level Limit

[Selector range 2-32] [Value range 0-9, default = 0]

Selector 2-32 = PAC 2-32. Sets the lowest security level that a PAC may select. Only useful if Value is set to 0 or 1. Otherwise, the system could not be disarmed or alarms canceled.

094.000.000 Duress PAC

[Selector range 2-32] [Value range 0-1, default = 0]

Selector 2-32 = PAC 2-32. The default Value of 0 programs a normal PAC. Setting the Value to 1 for the selected PAC, causes a duress report code to be sent to the Central Station when this PAC is used to arm or disarm the control (report code must be programmed). In all other respects the PAC operates normally.

095.000.000 Master PAC

[Selector range 2-32] [Value range 0-1, default = 0]

Selector 2-32 = PAC 2-32. The default Value of 0 programs a normal PAC. Setting the Value to 1 for the selected PAC programs a Master PAC. If the control is armed to Level 4 with a Master PAC, then only that PAC or another Master PAC may disarm.

096.000.000 Arm Only PAC

[Selector range 2-32] [Value range 0-1, default = 0]

Selector 2-32 = PAC 2-32. The default Value of 0 programs a normal PAC. Setting the Value to 1 for the selected PAC programs an Arm Only PAC. The PAC will only arm to Level 4. An Arm Only PAC may not disarm the control, independent of any other PAC settings.

097.000.000 No Bypass PAC

[Selector range 2-32] [Value range 0-1, default = 0]

Selector 2-32 = PAC 2-32. The default Value of 0 programs a normal PAC. Setting the Value to 1 for the selected PAC programs a No Bypass PAC. A No Bypass PAC cannot arm the system if any sensors are violated. Likewise, this type of PAC may not directly bypass sensors. Only meaningful if "Quick Arm" is disabled (see Function 121.012).

098.000.000 Access Output PAC

[Selector range 2-32] [Value range 0-1, default = 0]

Selector 2-32 = PAC 2-32. The default Value of 0 programs a normal PAC. Setting the Value to 1 for the selected PAC programs an Access Output PAC. If this feature is programmed, then each time this PAC is entered the Access Output is activated for the programmed time.

099.000.000 Access Output Only PAC

[Selector range 2-32] [Value range 0-1, default = 0]

Selector 2-32 = PAC 2-32. The default Value of 0 programs a normal PAC. Setting the Value to 1 for the selected PAC programs an Access Output Only PAC. A PAC code programmed with this feature cannot perform any security level changes. The user must enter a security level followed by his PAC code to activate the Access Output. The security level digit is ignored (no level change takes place and no tones will sound).

100.000.000 Locked PAC

[Selector range 2-32] [Value range 0-1, default = 0]

Selector 2-32 = PAC 2-32. The default Value of 0 programs a normal PAC. Setting the Value to 1 for the selected PAC programs a Locked PAC. This option keeps the user from changing their own PAC. Only a PAC set with programming privilege (Function 101) may change the code. Do not confuse this with Level 9 or system level programming access.

101.000.000 PAC Programming Enable

[Selector range 2-32] [Value range 0-1, default = 0]

Selector 2-32 = PAC 2-32. The default Value of 0 programs a normal PAC. Setting the Value to 1 for the selected PAC allows this PAC to program other PAC's. Otherwise a PAC may only change it's own code.

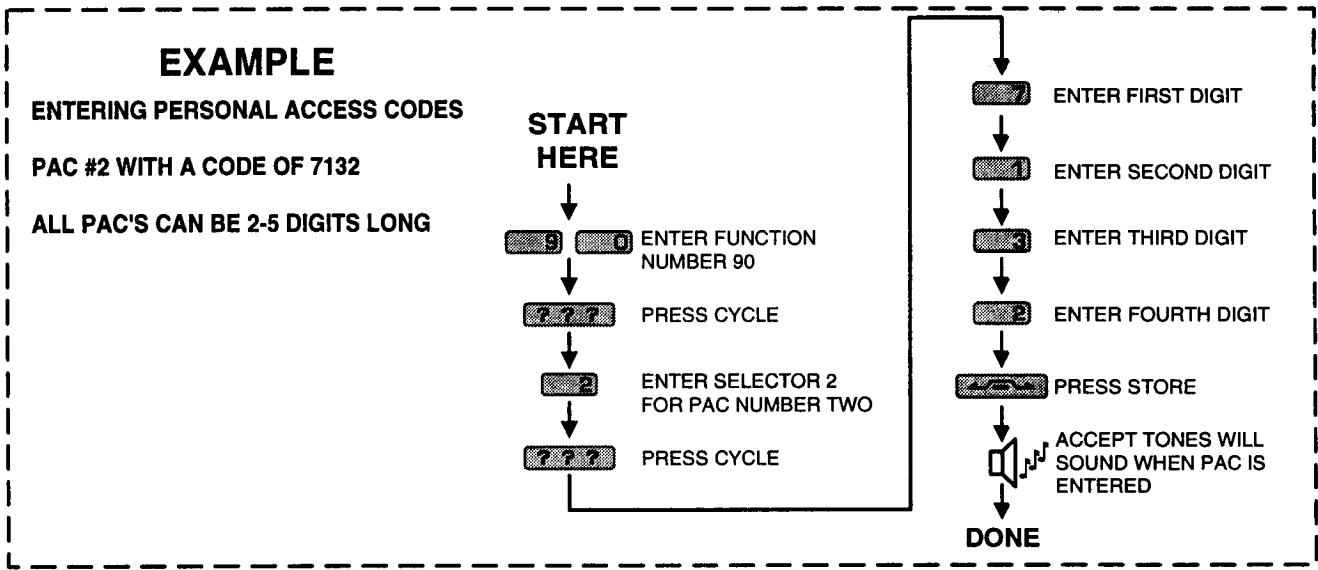

Figure 51. Example for Programming PAC Codes

PERSONAL ACCESS CODE (PAC) INSTALLATION					
FUNCTION	SELECTOR	VALUE	DEFAULT	DESCRIPTION	ACTION/VALUE
90	2-32			PERSONAL ACCESS CODE ENTRY	ENTER 2 TO 5 DIGITS, THEN PRESS STORE (PAC #1 IS TEMPORARY PAC)
91	2-32			CANCEL A PAC	PRESS STORE TO REMOVE PAC SELECTED
92	2-32	0-9	8	HIGH SECURITY LEVEL LIMIT	HIGHEST SECURITY LEVEL THIS PAC CAN USE
93	2-32	0-9	0	LOW SECURITY LEVEL LIMIT	LOWEST SECURITY LEVEL THIS PAC CAN USE
94	2-32	0-1	0	DURESS PAC	0 = NORMAL SECURITY LEVEL CONTROL 1 = THIS IS A DURESS PAC
95	2-32	0-1	0	MASTER PAC CODE	0 = NORMAL PAC CODE 1 = MASTER PAC CODE
96	2-32	0-1	0	ARM ONLY PAC	0 = NORMAL SECURITY LEVEL CONTROL 1 = ARMS TO LEVEL 4 ONLY
97	2-32	0-1	0	NO BYPASS PAC	0 = FULL BYPASS AUTHORITY 1 = NO BYPASS AUTHORITY
98	2-32	0-1	0	ACCESS OUTPUT PAC	0 = NO ACCESS CONTROL OUTPUT 1 = ACCESS CONTROL OUTPUT ACTIVATES
99	2-32	0-1	0	ACCESS OUTPUT ONLY	0 = NORMAL SECURITY LEVEL CONTROL 1 = ACTIVATE ACCESS OUTPUT ONLY
100	2-32	0-1	0	LOCKED PAC CODE	0 = USER CAN CHANGE OWN CODE 1 = USER CANNOT CHANGE OWN CODE
101	2-32	0-1	0	PAC PROGRAMMING ENABLE	0 = THIS PAC CANNOT SET OTHER PAC'S 1 = PAC PROGRAM MODE ALLOWED

Figure 52. Personal Access Code (PAC) Programming Table

CHANGING PACs OUTSIDE OF LEVEL 9

1. Disarm to Level 0 or 1 and press #
 2. Enter your current PAC.
 3. Press #
 4. Enter new PAC (2 to 5 digits long).
 5. Press #
 6. Listen for the accept tones.
- (Repeat steps or use a different code if not accepted.)

CHANGING TEMPORARY PAC OUTSIDE OF LEVEL 9

1. Disarm to Level 0 or 1 with a non-temporary PAC.
 2. Enter a permanent PAC and press #.
 3. Enter a digit from 1 to 9 for the number of times the PAC can be used (disarm then arm is two uses). Entering 0 will allow unlimited use.
 4. Press #
 5. Enter desired temporary PAC (2 to 5 digits long).
 6. Press #
 7. Listen for the accept tones.
- (Repeat steps or use a different code if not accepted.)

PRESS # PERMANENT PAC # # # # TO ERASE THE TEMPORARY PAC

CONTROL PANEL CONFIGURATION

Use the following Functions and Selectors to change Values for control panel configuration. Refer to the table in Figure 53. **The default values already in memory should be correct for most applications.**

NOTE: For each of the following functions, unless otherwise stated, pressing the STORE key causes the new Value to be stored into the CP-90's memory and the display will return to the Function field. If the command is accepted, the accept tones will sound.

120.001.000 **Entry Delay Time #1** [Value range 1-250, default = 30]

Sets the entry delay time #1. Delayed sensors can be programmed for entry delay #1 or #2 (Function 005). When the user enters the premises, violating sensors programmed for exit/entry delay, the entry timer is started. The keypad pre-alarm beeps may optionally be started at this time (Function 121.007). If the user has not disarmed the system before the entry time expires, an alarm will be triggered. Enter a Value in seconds if the default Value of 30 is unacceptable.

120.002.000 **Entry Delay Time #2** [Value range 1-250, default = 45]

Sets the entry delay time #2. Delayed sensors can be programmed for entry delay #1 or #2 (Function 005). When the user enters the premises, violating sensors programmed for exit/entry delay, the entry timer is started. The keypad pre-alarm beeps may optionally be started at this time (Function 121.007). If the user has not disarmed the system before the entry time expires, an alarm will be triggered. Enter a Value in seconds if the default Value of 45 is unacceptable.

120.003.000 **Exit Delay Time** [Value range 1-250, default = 45]

Sets the exit delay time. An exit delay is necessary in installations where the system control station is located inside the premises. When the user arms the CP-90, the exit delay timer is started in order to allow the user time to leave the premises and secure the entry/exit door. Enter a Value in seconds if the default Value of 45 is unacceptable.

NOTE: Be realistic! Allow enough time for the user to get out of the premises and secure the door.

If the entry/exit door is not secure when the exit time expires, an entry delay sequence will be started. If the CP-90 is not disarmed before the entry time expires, an alarm will be triggered.

120.004.000 **Burglary Output Delay** [Value range 0-250, default = 0]

Sets the delay for the Burglary Output on the control output connector. The delay gives the user time to disarm the system before the main audible alarm sounder starts. **This Value does not delay the keypad siren, only the Burglary Output.** The default Value of 0 gives the output no delay. Enter a different Value in seconds if a delay is required.

NOTE: In the following three Functions, entering 0 for the cutoff time will result in untimed alarms that will remain on until the system is disarmed. Untimed, unlimited alarms are not allowed by law in many locations. Check local ordinances for details.

120.005.000 **Burglary Output Cutoff Time** [Value range 0-250, default = 5]

Sets the cutoff time for the Burglary Output. The system will sound the alarm for the length of time specified by this Value. The default Value of 5 gives the output a 5 minute cutoff. Enter a different Value in minutes if a different time is required.

120.006.000 **Fire Output Cutoff Time** [Value range 0-250, default = 5]

Sets the cutoff time for the Fire Output. The system will sound the alarm for the length of time specified by this Value. The default Value of 5 gives the output a 5 minute cutoff. Enter a different Value in minutes if a different time is required.

120.007.000 **Police Alarm Cutoff Time** [Value range 0-250, default = 5]

Sets the cutoff time for the Police alarm. The system will sound the alarm for the length of time specified by this Value. The default Value of 5 gives the alarm a 5 minute cutoff. Enter a different Value in minutes if a different time is required.

120.008.000 **Emergency Output Cutoff Time** [Value range 0-250, default = 5]

Sets the cutoff time for the Emergency Output. The system will sound the alarm for the length of time specified by this Value. The default Value of 5 gives the output a 5 minute cutoff. Enter a different Value in minutes if a different time is required.

120.009.000 **Access Output On-Time** [Value range 0-250, default = 5]

Sets the Access Output on-time. Sensors programmed to the Access Only Zone will trigger the Access Output on the control output connector. This output is usually used to activate an electronic door strike. The default Value of 5 gives the output a 5 second on-time. Enter a different Value in seconds if a different time is required. Entering a Value of 0 causes the output to alternate from off to on and vice versa each activation.

120.010.000 **Automation #1 Output On-Time** [Value range 0-250, default = 5]

Sets the Automation #1 Output on-time. Sensors programmed to the Automation #1 Zone will trigger the Automation #1 Output on the control output connector. This output is usually used to activate an external device. The default Value of 5 gives the output a 5 second on-time. Enter a different Value in seconds if a different time is required. Entering a Value of 0 causes the output to alternate from off to on and vice versa each activation.

120.011.000 **Automation #2 Output On-Time** [Value range 0-250, default = 5]

Sets the Automation #2 Output on-time. Sensors programmed to the Automation #2 Zone will trigger the Automation #2 Output on the control output connector. This output is usually used to activate an external device. The default Value of 5 gives the output a 5 second on-time. Enter a different Value in seconds if a different time is required. Entering a Value of 0 causes the output to alternate from off to on and vice versa each activation.

121.001.000 **Pulsing Burglary Output** [Value range 0-1, default = 0]

Controls the Burglary Output on the control output connector. The default Value of 0 causes a steady output on alarm. Enter a Value of 1 for a pulsed output (one second on, one second off) on alarm.

CONTROL PANEL CONFIGURATION

FUNCTION	SELECTOR	VALUE	DEFAULT	DESCRIPTION	ACTION/VALUE
120	1	1-250	30	ENTRY DELAY TIME #1	ENTER VALUE IN SECONDS FOR DELAY
120	2	1-250	45	ENTRY DELAY TIME #2	
120	3	1-250	45	EXIT DELAY TIME	
120	4	0-250	0	BURGLARY OUTPUT DELAY	
120	5	0-250	5	BURGLARY OUTPUT CUTOFF	ENTER VALUE IN MINUTES ENTER "0" FOR CONTINUOUS
120	6	0-250	5	FIRE OUTPUT CUTOFF	
120	7	0-250	5	POLICE ALARM CUTOFF	
120	8	0-250	5	EMERGENCY OUTPUT CUTOFF	
120	9	0-250	5	ACCESS OUTPUT ON-TIME	ENTER ACCESS OUTPUT TIME IN SECONDS 0 = TOGGLES ON/OFF EACH ACTIVATION
120	10	0-250	5	AUTOMATION #1 ON-TIME	
120	11	0-250	5	AUTOMATION #2 ON-TIME	
121	1	0-1	0	PULSING BURGLARY OUTPUT	0 = STEADY
121	2	0-1	1	PULSING FIRE OUTPUT	1 = ONE SECOND ON & ONE SECOND OFF
121	3	0-1	0	MULTIPLE BURGLARY OUTPUT SHUTDOWN	0 = MULTIPLE OUTPUTS PER ARM/DISARM; 1 = ONLY ONE AUDIBLE OUTPUT PER ARM
121	4	0-1	0	DAY ALERT LATCH	0 = TROUBLE LIGHT CLEARS WHEN NO TROUBLE; 1 = TROUBLE LIGHT LATCHES
121	5	0-1	0	BELL TEST ON ARMING	0 = NO BELL TEST; 1 = BELL TEST IN LEVEL 4 AT CENTRAL STATION KISSOFF
121	6	0-1	0	KEYPAD BURGLARY FOR LOCK-INS	0= NORMAL; 1 = ANY KEY STARTS ENTRY DELAY WHILE IN LEVEL 4
121	7	0-1	1	ENTRY DELAY BEEPS	0 = BEEPS OFF
121	8	0-1	1	EXIT DELAY BEEPS	1 = BEEPS ON
121	9	0-1	0	SILENT POLICE ALARMS	0 = ALARM WILL SOUND 1 = SILENT ALARM
121	10	0-1	0	SILENT EMERGENCY ALARMS	
121	11	0-1	0	SILENT BURGLARY ALARMS	
121	12	0-1	0	DISABLE QUICK ARMING	0 = QUICK ARMING ALLOWED; 1 = QUICK ARMING NOT ALLOWED
121	13	0-1	0	AUTOMATIC RESTORAL	0 = BYPASSES CLEAR ON RESTORAL; 1 = BYPASSES REMAIN ON RESTORAL
121	14	0-1	0	AUTO BYPASS ARMING	0 = AUTO BYPASS THEN ARM; 1 = NO ARM UNTIL MANUAL BYPASS
121	15	0-1	0	RECEIVER DESENSE	0 = NORMAL RECEIVER SENSITIVITY; 1 = REDUCED RECEIVER SENSITIVITY (-5 dB)
121	16	0-1	0	ALARM LATCH FOR NON-REPORTING SENSORS	0 = NO ALARM MEMORY OR ALARM LED; 1 = ALARM MEMORY & LED LATCHES
121	17	0-1	0	AUTOMATIC ALARM MEMORY DISPLAY	0 = MANUAL ALARM MEMORY DISPLAY ONLY WITH STATUS "96" 1 = AUTO ALARM MEMORY DISPLAY FOR 45 SECONDS AFTER ALARM
121	18	0-1	0	24-HOUR SYSTEM STATUS DISPLAY	0 = STATUS INDICATORS ONLY WHEN MANUALLY CHECKING STATUS 1 = SENSOR STATUS SHOWN ON INDICATORS AT ALL TIMES
121	19	0-1	0	KD-90 COMMUNICATOR STATUS DISPLAY	0 = NO COMMUNICATOR STATUS DISPLAY 1 = COMM. STATUS DISPLAYED ON KD-90
121	20	0-1	0	MASTER RESET DISABLE	0 = MASTER RESET SWITCH ENABLED; 1 = MASTER RESET SWITCH DISABLED
121	21	0-1	0	EVENT LOG LIMITER	0 = NO LIMITS ON ADDING TO THE EVENT LOG 1 = ONLY 200 EVENTS WILL BE LOGGED AFTER INITIAL ALARM UNTIL LOG IS CLEARED
121	22	0-1	0	AUDIBLE SENSOR TROUBLE	0 = SENSOR TROUBLE ONLY LIGHTS LEDS ON KEYPADS 1 = SENSOR TROUBLE LIGHTS LEDS ON KEYPADS AND CHIMES EVERY MINUTE
121	23	0-1	0	QUICK BYPASS DISABLE	0 = QUICK BYPASSING ALLOWED 1 = QUICK BYPASSING NOT ALLOWED (MANUAL SENSOR BYPASSING REQUIRED)
122	1	0-1	1	SENSOR VIOLATION & TEST LOGGING INCLUDING UNARMED SENSORS	0 = LOG ONLY ARMED SENSORS ALARMS 1 = LOG ALL SENSOR VIOLATIONS & SENSOR TESTS
122	2	0-1	1	SENSOR RESTORAL LOGGING	0 = NO LOGGING; 1 = LOG EVENTS
122	3	0-1	1	NORMAL OPENING & CLOSING LOGGING	0 = NO LOGGING; 1 = LOG EVENTS
122	4	0-1	1	FORCED CLOSING LOGGING	0 = NO LOGGING; 1 = LOG EVENTS
122	5	0-1	1	OPENING AFTER AN ALARM LOGGING	0 = NO LOGGING; 1 = LOG EVENTS
122	6	0-1	1	SENSOR & ACCESSORY SUPERVISORY LOGGING	0 = NO LOGGING; 1 = LOG EVENTS
122	7	0-1	1	PANEL RESET, TEST & SUPERVISORY LOGGING	0 = NO LOGGING; 1 = LOG EVENTS
122	8	0-1	1	COMMUNICATOR LOGGING	0 = NO LOGGING; 1 = LOG EVENTS
122	9	0-1	1	PANEL PROGRAMMING LOGGING	0 = NO LOGGING; 1 = LOG EVENTS
122	10	0-1	1	FIRE, BURG AND EMERGENCY OUTPUTS LOGGING	0 = NO LOGGING; 1 = LOG EVENTS (OUTPUT ON & OFF)

Figure 53. Control Panel Configuration Table

121.002.000**Pulsing Fire Output
[Value range 0-1, default = 1]**

Controls the Fire Output on the control output connector. The default Value of 1 causes a pulsed output (one second on, one second off) on alarm. Enter a Value of 0 for a steady output on alarm.

121.003.000**Multiple Burglary Output Shutdown
[Value range 0-1, default = 0]**

Controls how many times the Burglary Output can activate during one arming period. The default Value of 0 allows unlimited alarm activations after each cutoff time (Function 120.005). Entering 1 for this Value allows only one activation of the Burglary Output for each time the system is armed. This Value only affects the Burglary Output on the control output connector and does not affect other types of alarms or alarm reports to the central station (they can be limited by the swinger count with Function 050.015).

121.004.000**Day Alert Latch
[Value range 0-1, default = 0]**

Latches the TROUBLE light on keypads. When sensors or accessories report trouble, (supervisory, low battery, tamper, etc.) the TROUBLE light on the wired keypads will blink. The default Value of 0 causes the TROUBLE light to automatically clear (go out) when the cause of the trouble is corrected. Entering 1 for this Value will cause the TROUBLE light to latch on until it is manually reset with the command "STATUS 97" entered in Level 0 on any wired keypad.

121.005.000**Bell Test on Arming
[Value range 0-1, default = 0]**

Causes the Burglary Output to activate for 1 second when the system is armed in Level 4 (away mode). The bell test occurs after the closing report communication to the central station is completed. If closing reports are disabled or the communicator is turned off, the bell test occurs as soon as Level 4 is entered. The default Value of 0 disables the bell test. Enter a Value of 1 if bell test is required.

121.006.000**Keypad Burglary for Lock-ins
[Value range 0-1, default = 0]**

Causes an entry delay to start when any keypad key is pressed if the system is armed in Level 4 (away mode). This feature is useful in installations where someone might try to compromise the system by staying inside the secured premises. The default Value of 0 disables this feature. Enter a Value of 1 if keypad burglary for lock-in is required.

121.007.000**Entry Delay Beeps
[Value range 0-1, default = 1]**

Turns entry delay beeps on and off. The default Value of 1 causes the keypad(s) to sound beeps during the entry delay. This alerts the user that the system must be disarmed or an alarm will occur. Entering 0 for this Value will cause the entry delay to be silent. **Silent burglary sensors and alarms will not sound the entry delay beeps.**

121.008.000**Exit Delay Beeps
[Value range 0-1, default = 1]**

Turns exit delay beeps on and off. The default Value of 1 causes the keypad(s) to sound beeps during the exit delay. This alerts the user that the premises must be vacated and secured before the delay time expires. Entering 0 for this Value causes the exit delay to be silent.

121.009.000**Silent Police Alarms
[Value range 0-1, default = 0]**

Disables sounders for police alarms. The default Value of 0 allows for audible police alarms. Entering 1 for this Value will cause all sensors and keypad buttons that trigger the police/hold-up zone to produce silent alarms. The communicator must be turned on (Function 050.001) to use this feature.

121.010.000**Silent Emergency Alarms
[Value range 0-1, default = 0]**

Disables sounders for emergency alarms. The default Value of 0 allows for audible emergency alarms. Entering 1 for this Value will cause all sensors and keypad buttons that trigger the emergency zone to produce silent alarms. The communicator must be turned on (Function 050.001) to use this feature.

121.011.000**Silent Burglary Alarms
[Value range 0-1, default = 0]**

Disables sounders for burglary alarms. The default Value of 0 allows for audible burglary alarms. Entering 1 for this Value will cause all sensors that trigger the burglary zone to produce silent alarms. **Entry delay beeps will not sound.** The communicator must be turned on (Function 050.001) to use this feature.

121.012.000**Disable Quick Arming
[Value range 0-1, default = 0]**

Disables the "Quick Arming" keypad feature. The default Value of 0 allows the user to arm the system to Levels 1-6 simply by holding down the associated keypad number button (1-6) for about 1 second. "Quick Arming" can only change the system into a higher security level than it's currently in. Enter a value of 1 to disable "Quick Arming".

121.013.000**Automatic Bypass Restoral
[Value range 0-1, default = 0]**

Allows bypassed sensors to automatically remove their bypass when they restore. Violated sensors can be bypassed when the system is armed either automatically (when arming from a remote) or manually from the keypad. With the default Value of 0, when the sensor restores, the bypass will be removed. The formerly bypassed sensor will then be ready to cause a violation. Entering 1 for this Value causes the sensor(s) to remain bypassed until the system is disarmed.

121.014.000**Automatic Bypass Arming
[Value range 0-1, default = 0]**

Allows for automatically bypassing violated sensors when arming. With the default Value of 0, if the system is armed with violated sensors, 45 seconds after the rejection tones sound the system will automatically bypass all violated sensors and arm to the security level selected. Entering 1 for this Value requires that sensors be manually bypassed before the system can be armed.

121.015.000**Receiver Desense
[Value range 0-1, default = 0]**

Reduces the CP-90's RF receiver sensitivity for testing and high noise environments. The default Value of 0 allows for full receiver sensitivity. Entering 1 for this Value will reduce the receiver's sensitivity by 6 db (approximately 50%).

121.016.000**Alarm Latch for Non-reporting Sensors****[Value range 0-1, default = 0]**

Allows latching of the ALARM light and alarm memory on the keypad for sensors that cause a violation but no report when the system is disarmed. The default Value of 0 only allows the ALARM light to latch and the alarm memory to display sensors that cause a violation and a report while the system is armed. Entering a Value of 1 causes non-reporting sensors (Guard Zone, Environmental B & C Zones) that cause a local alarm but no report to latch the ALARM light and show in the alarm memory.

☞ **NOTE:** *The Guard Zone does report in Level 4.*

121.017.000**Automatic Alarm Memory Display****[Value range 0-1, default = 0]**

Causes the keypads to automatically display the alarm memory sequence after an alarm. The keypad's display will show the alarm memory sequence for 45 seconds. The default Value of 0 disables this feature and pressing STATUS "96" is required to display the alarm memory. Enter a Value of 1 to enable the automatic alarm memory feature.

121.018.000**24-Hour System Status Display****[Value range 0-1, default = 0]**

Causes the corresponding keypad status indicators to flash on idle keypads when one or more sensors or accessories are faulted. The default Value of 0 disables this feature. Enter a Value of 1 to enable the 24-hour system status display. This feature is disabled during duress alarms.

☞ **NOTE:** *This Value must be set to 1 for UL installations.*

121.019.000**KD-90 Communicator Status Display****[Value range 0-1, default = 0]**

Causes KD-90 keypads to display the status of the communicator. Messages such as "COMMUNICATOR ON LINE", "COMMUNICATOR DIALING", "REMOTE PANEL ACCESS" are displayed on the bottom line of the KD-90 display. This feature lets the user know that the CP-90 is accessing the phone line. The default Value of 0 disables this feature. Enter a Value of 1 to enable the communicator status display. This feature is disabled during duress alarms.

121.020.000**Master Clear Disable****[Value range 0-1, default = 0]**

Disables the master clear function preventing unauthorized erasing of the program memory. The default Value of 0 allows the MASTER RESET switch to operate as normal. Enter a Value of 1 to disable the master clear function invoked by the MASTER RESET switch.

121.021.000**Event Log Limiter****[Value range 0-1, default = 0]**

Limits entries to the internal event log after an alarm. The CP-90 logs many system events. Logged events are time tagged with one minute resolution and are stored in chronological order. The event log buffer can store up to 300 events. After the first 300 events, as more events are stored, the oldest event is erased to make room for the new event.

The default Value of 0 allows unlimited entries to the event log. Entering a Value of 1 will limit the log to only accepting 200 more entries after the initial alarm. This prevents losing alarm history in the case of a runaway sensor. The log limit is reset clearing the log limit counter with the CP-90RA Remote Access Program.

121.022.000**Audible Sensor Trouble****[Value range 0-1, default = 0]**

Causes the keypads to sound the trouble sounder every minute when any sensor has a low battery or supervisory trouble. The default Value of 0 disables audible sensor trouble. Entering a Value of 1 enables audible sensor trouble. The system warning beep can be canceled before fixing the sensor trouble by pressing the * key on the keypad.

☞ **NOTE:** *This Value must be set to 1 for UL installations.*

121.023.000**Quick Bypass Disable****[Value range 0-1, default = 0]**

Disables the quick bypass feature. The default Value of 0 allow quick bypassing of violated sensors while arming. Entering a Value of 1 will disable quick bypassing, causing the user to manually bypass each violated sensor while arming.

☞ **NOTE:** *This Value must be set to 1 for UL installations.*

122.001.000**Sensor Violation & Test Logging****[Value range 0-1, default = 0]**

Causes all sensor violations and test reports to be stored in the event log. **This includes unarmed sensors.** Violations from armed sensors, 24-hour zones and keypad emergencies are always logged. The default Value of 0 requires that the sensor be armed before violations will be entered into the event log. Entering a Value of 1 will cause all violations and test reports to be logged.

122.002.000**Sensor Restoral Logging****[Value range 0-1, default = 1]**

Causes sensor restore reports from armed sensors to be stored in the event log. The default Value of 1 will cause these reports to be logged. Entering a Value of 0 prevents these reports from being logged. If a Value of 1 is entered for 122.001, all sensor restorals are logged.

122.003.000**Normal Opening & Closing Logging****[Value range 0-1, default = 1]**

Causes all normal opening and closing events (closes without bypasses and openings without pending alarms) to be stored in the event log. The default Value of 1 will cause these events to be logged. Entering a Value of 0 prevents these events from being logged.

122.004.000**Forced Closing Logging****[Value range 0-1, default = 1]**

Causes all forced closing events (closes with bypassed sensors) to be stored in the event log. The default Value of 1 will cause these events to be logged. Entering a Value of 0 prevents these events from being logged.

122.005.000**Opening After an Alarm Logging****[Value range 0-1, default = 1]**

Causes all opening events occurring after an alarm and alarm cancels to be stored in the event log. The default Value of 1 will cause these events to be logged. Entering a Value of 0 prevents these events from being logged.

122.006.000**Sensor & Accessory Supervisory Logging****[Value range 0-1, default = 1]**

Causes all sensor and accessory supervisory events to be stored in the event log. The default Value of 1 will cause these events to be logged. Entering a Value of 0 prevents these events from being logged.

SPECIAL INSTALLER FUNCTIONS					
FUNCTION	SELECTOR	VALUE	DEFAULT	DESCRIPTION	ACTION/VALUE
123	1			DELETE ALL SENSORS	CYCLE TO VALUE FIELD AND PRESS STORE TO DELETE ALL SENSORS
123	2			DELETE ALL ACCESSORIES	CYCLE TO VALUE FIELD AND PRESS STORE TO DELETE ALL ACCESSORIES
123	3			DELETE ALL PAC CODES	CYCLE TO VALUE FIELD AND PRESS STORE TO DELETE ALL PAC CODES
123	4			RE-ASSIGN SENSOR REPORT CODES	CYCLE TO VALUE FIELD AND PRESS STORE TO RE-ASSIGN SENSOR REPORT CODES TO VALUES IN REPORT CODE TABLE (SEE FUNCTIONS 70 & 75)

Figure 54. Special Installer Functions Table

122.007.000 Panel Reset, Test & Supervisory Logging
[Value range 0-1, default = 1]

Causes all control panel reset, test and supervisory events to be stored in the event log. The default Value of 1 will cause these events to be logged. Entering a Value of 0 prevents these events from being logged.

NOTE: Resetting the control panel will erase all data in the event log.

122.008.000 Communicator Logging
[Value range 0-1, default = 1]

Causes all communicator attempts, successes and failures to be stored in the event log. The default Value of 1 will cause these events to be logged. Entering a Value of 0 prevents these events from being logged.

122.009.000 Panel Programming Logging
[Value range 0-1, default = 1]

Causes all entries and exits, local and remote, to programming Level 9 to be stored in the event log. The default Value of 1 will cause these events to be logged. Entering a Value of 0 prevents these events from being logged.

122.010.000 Fire, Burglary & Emergency Outputs Logging
[Value range 0-1, default = 1]

Causes all activations and deactivations of the fire, burglary and emergency control outputs to be stored in the event log. The default Value of 1 will cause these events to be logged. Entering a Value of 0 prevents these events from being logged.

SPECIAL INSTALLER FUNCTIONS

123.001.000 Delete All Sensors

Deletes all sensors from the CP-90 memory. Cycle to the Value field and press STORE to delete all sensors. The accept tones will sound when the sensors are deleted.

123.002.000 Delete All Accessories

Deletes all accessories from the CP-90 memory. Cycle to the Value field and press STORE to delete all accessories. The accept tones will sound when the accessories are deleted. The current keypad being used will be automatically re-installed as accessory #65.

123.003.000 Delete All PAC Codes

Deletes all PAC codes from the CP-90 memory. Cycle to the Value field and press STORE to delete all PAC codes. The accept tones will sound when the PAC codes are deleted. The default for PAC #32 is restored to 98765.

123.004.000 Re-assign Sensor Report Codes

Re-assigns all sensor report codes using current Values in the report code table. If sensors are installed prior to selecting the proper communicator format and/or changing the report code defaults, this will automatically assign new report codes for each sensor based on the sensor zone type and the corresponding value in the report code table.

Cycle to the Value field and press STORE to re-assign all sensor report codes. The accept tones will sound when the function is complete.

SYSTEM TESTING

To assure continued protection, Linear recommends that the CP-90 be tested weekly. The system features two special levels (Level 7 and Level 8) for testing.

Level 7 Telephone Test

If the system is monitored, this level tests the telephone connection between the system and the Central Monitoring Station.

☞ **NOTE:** With all communicator formats except SuperSpeed and SIA the communicator manual test (Functions 070.018 & 075.018) must be enabled before this test will work.

- ① Switch to Level 7; the level change gong and seven level count beeps will sound.
- ② Wait for test to complete.
- ③ If the test passes, the system will sound the accept tones and switch to Level 0 when test is complete.
- ④ If the test fails, the system will switch to Level 0 without sounding the accept tones in about 4 minutes.
- ⑤ Verify that the central station received the call correctly.

Level 8 Sensor Test

This level tests the radio link between each sensor and the control panel. Two different types of tests can be made. The *standard test* is for testing all sensors. The *individual test* is for testing specific sensors.

Standard Complete System Test

- ① Switch to Level 8; the level change gong and eight level count beeps will sound.
- ② The display will show each sensor number in order.
- ③ Activate each sensor.
- ④ As each sensor is activated, the sensor test beep will sound and the sensor number will be *removed* from the display.
- ⑤ Test keypads by quickly pressing each emergency key.
- ⑥ Continue testing until all sensor numbers have been removed from the display.
- ⑦ When all sensors and accessories have been tested, the accept tones will sound.

Individual Sensor Test

- ① Switch to Level 8, the level change gong and eight level count beeps will sound.
- ② Press STATUS.
- ③ Display will show the last sensor activated.
- ④ Activate sensor(s); the sensor test beep will sound when a sensor is activated.
- ⑤ Check display for sensor number.

☞ **NOTE:** The system will automatically switch from Level 8 back to Level 0 after 4 minutes.

How to Test Door and Window Sensors

- ① Open door or window or press the sensor's test button; listen for sensor test beep.
- ② Close door or window.

How to Test Motion Detectors

- ① Stay out of protected area for **at least 5 minutes**.
- ② Walk through the protected area; listen for sensor test beep.

How to Test Smoke Detectors

- ① Press and hold the smoke detector test button until detector starts beeping.
- ② Hold for an additional 15 seconds; listen for the sensor test beep.

How to Test Keypads (Sensors 65-72)

* **CAUTION: DO NOT HOLD THE KEYPAD EMERGENCY BUTTONS FOR MORE THAN 1 SECOND WHILE TESTING! THE ALARM WILL BE TRIGGERED.**

- ① Quickly press the fire button; listen for sensor test beep.
- ② Quickly press the emergency button; listen for sensor test beep.
- ③ Quickly press the police button; listen for sensor test beep.
- ④ Check display, the keypad's sensor number should be gone.

How to Test Portable Sensors

- ① Press the portable sensor's button; listen for sensor test beep.

How to Test Panic Buttons

- ① Transmitters programmed as zone types 7 or 8 require holding the transmitter's button down for approximately 3 seconds.

A

AC Power Failure 9, 36, 38
 AC Power Restore 36, 38
 Accept Tones 7
 Access Only Zone 5
 Access Output On Time 44
 Accessories 65-72 24
 Accessory Installation 24
 Accessory Supervisory Trouble 9
 Accessory Tamper 9
 Active Display Intensity 24
 Active Downtight Intensity 24
 Active Lighting Level 4
 Alarm Call Routing 30
 Alarm Latch for Non-reporting Sensors 47
 Alarm Light 47
 Alarm Memory 47
 Alarm Tone Loudness 24
 Annunciation Loudness 24
 Anti-Jam Time 28
 Arm/Disarm Toggle 5
 Audible Sensor Trouble 47
 Audible Signals and Sirens 7
 Audio Events Call Routing 30
 Audio Reporting 20
 Auto-install RF Sensors 18
 Automatic Alarm Memory Display 47
 Automatic Bypass Arming 46
 Automatic Bypass Restoral 46
 Automatic Test 38
 Automatic Test Report Delay 28
 Automatic Test Report Interval 28
 Automatic/Manual Test Call Routing 30
 Automation #1 Output On Time 44
 Automation #1 Zone 5
 Automation #2 Output On Time 44
 Automation #2 Zone 5
 Auxiliary Fuse Blown 37
 Auxiliary Fuse Failure 9
 Away Security Level 6

B

Backup Battery Testing 8
 Basic Keypad Operation 7
 Basic System Information 5
 Bell Test on Arming 46
 Burglar Alarm Output Delay 44
 Burglary Output Cutoff Time 44
 Bypass Key 12
 Bypassed Sensor/Loop 34
 Bypassing 20

C

Cancel 36
 Cancel a PAC 42
 Chime Only Zone 5
 Chime Security Level 6
 Chime Tones 7
 Clear/Exit Key 12
 Clearing Trouble Displays 8
 Clock, Setting the KD-90 8
 Closing 36, 38
 Closing Reports by Exception 26
 Communication Failure 37
 Communicator Automatic Test 36
 Communicator Format #1 26
 Communicator Format #2 26
 Communicator Logging 48
 Communicator Manual Test 36
 Communicator On/Off 26
 Communicator Routing & Phone Numbers 30
 Control Panel Battery Restore 36, 38
 Control Panel Configuration 44
 Control Panel Door Tamper 36
 Control Panel Low Battery 36, 38
 Control Station Keys During Programming 12
 Control Station Numbers 15
 Copy Primary Setup to Secondary 32
 Copy Secondary Setup to Supervisory 32
 Count Down Key 12
 Count Up Key 12
 Cycle Key 12

D

Day Alert Latch 46
 Default Report Code Override 37...38
 Delayed Remote Emergency 5
 Delayed Remote Police/Hold-up 5
 Delete All Accessories 48
 Delete All PAC Codes 48
 Delete All Sensors 48
 Dial Attempts Before Routing Change 28
 Dial Attempts Before Sleep Cycle 28
 Dialing Format 26
 Dialing Start Delay 26
 Disable Quick Arming 46
 Disarm/Cancel Security Level 6
 Display Accessories 24
 Displaying Installed Sensors 18
 Duress 36, 42

E

EEPROM Write Failure 9
 Emergency Fire Alarm 7
 Emergency Intrusion Alarm 7
 Emergency Key Audio 24
 Emergency Output Cutoff Time 44
 Emergency Zone 5
 Emergency Zone Report Code 34
 Entering Programming Level 12
 Entry Delay 20
 Entry Delay After Alarm Beeps 7
 Entry Delay Beeps 7, 46
 Entry Delay Time #1 44
 Entry Delay Time #2 44
 Environmental Alarm Sounder 7
 Environmental Type A Report Code 34
 Environmental Type A Zone 5
 Environmental Type B Zone 5
 Environmental Type C Zone 5
 Event Log Limiter 47
 Exit Delay Beep 46
 Exit Delay Beeps 7
 Exit Delay Time 44
 Exiting Programming Levels 12
 Exterior Intrusion 34
 Exterior Zone 5

F

Factory Defaults 3
 Fire Fuse Blown 37
 Fire Fuse Failure 9
 Fire Output Cutoff Time 44
 Fire Sensor/Loop 34
 Fire Zone 5
 Fire, Burglary & Emergency Outputs Logging 48
 First Time Power Up 3
 Force Arm 38
 Force Close 37
 Forced Closing Logging 47
 Function Field 13
 Functions, Selectors & Values 10

G

General Communicator Operation 26
 Guard Zone 5
 Guard/Cancel Security Level 6

H

Hardwire Loop Auto Setup 22
 Hardwire Loop Disable 22
 Hardwire Loop Response Time 22
 Hardwire Loop Supervision 22
 Hardwire Loop Trouble Type 22
 Home Security Level 6

I

Inhibit SuperSpeed ETX Signal 28
 Installed Connected Accessories 24
 Interior Intrusion 34
 Interior Zone 5
 Internal Diagnostic Checks 3
 Invalid Access Timeout 28

K

KD-90 Communicator Status Display 47
 Keypad Burglary for Lock-ins 46
 Keypad Code 42
 Keypad Emergency 34
 Keypad Emergency Keys 24
 Keypad Fire 34
 Keypad Lighting 4
 Keypad Lockout Timer 4
 Keypad Police/Hold Up 34
 Keypad Supervision 4
 Keypad Tamper 36
 Keypad Test 49
 Keypad Trouble 37
 Keystroke Beep Loudness 24

L

LCD Keypad Captions 22, 24
 Level Change Gong 7
 Level Count Beeps 7
 Lights On During Entry Delay 24
 Lights On During Exit Delay 24
 Listen-only Audio After Duress PAC 28
 Local Alarm 20
 Loop Response Time 22
 Low Backup Battery 9

M

Manual Backup Battery Test 8
 Manual Test 38
 Manually Install RF Sensors 18
 Manually Remove RF Sensors 18
 Master Clear Disable 47
 Master Reset Switch 3
 MegaCode Format 16
 Memory Error 37
 Multiple Burglary Output Shutdown 46

N

Night Secure Security Level 6
 Night Security Level 6
 Normal Opening & Closing Logging 47
 Number of Sleep Cycles Allowed 28

O

Open/Close Call Routing 30
 Opening 36, 38
 Opening After an Alarm Logging 47
 Opening Reports by Exception 26

P

PACs
 Access Output 42
 Access Output Only 42
 Arm Only 42
 Cancel 42
 Duress 42
 High Security Level Limit 42
 Locked 42
 Low Security Level Limit 42
 Master 42
 No Bypass 42
 PAC Programming Enable 42
 Panel AC Power Failure 9
 Panel Auxiliary Fuse Failure 9
 Panel Fire Fuse Failure 9
 Panel Low Battery 9
 Panel Power Failure 9
 Panel Programming Logging 48
 Panel Radio Failure 9
 Panel Reset, Test & Supervisory Logging 48
 Panel Tamper Condition 9
 Personal Access Code Entry 42
 Personal Access Code Installation 42
 Personal Emergency Sounder 7
 Phone Test Level 6
 Police Alarm Cutoff Time 44
 Police/Hold Up 34
 Police/Hold-up Emergency Alarm 7
 Police/Hold-up Zone 5
 Power Failure 9
 Power-up Indications 4
 Primary Line Account Number 32
 Primary Line Format 30
 Primary Line Telephone Number 32
 Program Descriptions 18
 Programming 12
 Programming Cycle 13
 Programming Level 12
 Programming Level Timer 4, 12
 Programming Mode 6
 Pulsing Burglary Output 44
 Pulsing Fire Output 46

Q

Quick Bypass Disable 47

R

Radio Failure 9
 Re-assign Sensor Report Codes 48
 Receiver Desense 46
 Rejection Tones 7
 Remote Program Access Code 28
 Remote Programming Lockout 28
 Remove Installed Accessories 24
 Reporting Codes 34
 AC Failure 36, 38
 AC Restore 36, 38
 Automatic Test 38
 Auxiliary Fuse Blown 37
 Bypassed Sensor/Loop 34
 Cancel 36
 Closing 36, 38
 Communication Failure 37
 Communicator Automatic Test 36
 Communicator Manual Test 36
 Control Panel Battery Restore 36, 38
 Control Panel Door Tamper 36
 Control Panel Low Battery 36, 38
 Default Report Code Override 37
 Duress 36
 Emergency 34
 Environmental 34
 Exterior Intrusion 34
 Fire Fuse Blown 37
 Fire Sensor/Loop 34
 Force Arm 38
 Force Close 37
 Interior Intrusion 34
 Keypad Emergency 34
 Keypad Fire 34
 Keypad Police/Hold Up 34
 Keypad Tamper 36
 Keypad Trouble 37
 Manual Test 38
 Memory Error 37
 Opening 36, 38
 Police/Hold Up 34
 Restore 34

Sensor Low Battery 37...38
 Sensor Supervisory Trouble 37
 Sensor Tamper 34
 Sensor/Loop Restore 38
 Sensor/Loop Supervisory 38
 Sensor/Loop Tamper 38
 Supervisory Trouble 36, 38
 Reporting Codes for Extended Formats 40
 Reset to Default Key 12
 Restore 34
 Restore Call Routing 30
 Restoring Factory Defaults 3
 Restricted Interior Zone 5
 RF Sensor Supervision 20
 RF Sensor Type 20

S

S1 Format 16
 Secondary Line Account Number 32
 Secondary Line Format 30
 Secondary Line Telephone Number 32
 Security Levels 6
 Selector Field 13
 Sensor & Accessory Supervisory Logging 47
 Sensor Audio Reporting 20
 Sensor Bypassing 20
 Sensor Entry Delay 20
 Sensor Installation 18
 Sensor Local Alarm 20
 Sensor Low Battery 9, 37...38
 Sensor Numbers 15
 Sensor Restoral Logging 47
 Sensor Setup 16
 Sensor Supervisory 9
 Sensor Supervisory Trouble 37
 Sensor Tamper 9, 34
 Sensor Test 49
 Sensor Test Beep 7
 Sensor Test Level 6
 Sensor Violation & Test Logging 47
 Sensor Zone Type 20
 Sensor/Loop Restore 38
 Sensor/Loop Supervisory 38
 Sensor/Loop Tamper 38
 Sensors 1-64 18
 Setting KD-90 Clock 8
 Silent Burglar Alarms 46
 Silent Emergency Alarms 46
 Silent Police Alarms 46
 Sleep Cycle Time 28
 Special Keypad Commands 8
 Special Trouble Displays 9
 Standby Display Intensity 24
 Standby Downtight Intensity 24
 Standby Lighting Level 4
 Status Key 12
 Status Key Commands 8
 Store Key 12
 SuperSpeed, SIA & Ademco Reporting Codes 40
 Supervisory Line Account Number 33
 Supervisory Line Format 30
 Supervisory Line Telephone Number 33
 Supervisory Restore 37
 Supervisory Trouble 36, 38
 Supervisory/Trouble Call Routing 30
 Swinger Eliminator Count 28
 SX Format 16
 System Power Up 3
 System Tasting 49
 System Zones 5

T

Tamper Condition 9
 Tamper Reports 26
 Telephone Test 49
 Test Levels 6
 Transmitter Setup 16
 Trouble Display Codes 9
 Trouble Light 3
 24-Hour System Status Display 47
 TX Button Disable Zone 5
 TX Type Transmitter Zone Select 22

U

Uninstalled Accessory 9

V

Value Field 13

W

Watchdog Monitor 3, 9

Z

Zones 5

FCC NOTICE

This equipment generates and uses radio frequency energy and if not installed and used properly, that is, in strict accordance with the manufacturer's instructions, may cause interference to radio and television reception. It has been type tested and found to comply with the limits for a Class B computing device in accordance with Part 15 of FCC Rules, which are designed to provide reasonable protection against such interference in a residential installation. However, there is no guarantee that interference will not occur in a particular installation. If this equipment does cause interference to radio or television reception, which can be determined by turning the equipment off and on, the user is encouraged to try to correct the interference by one or more of the following measures:

- Relocate the CP-90 away from the TV/radio receiver.
- Plug the CP-90 into a different wall outlet so that the console is on a different branch circuit.
- Re-orient the TV/radio antenna.

If necessary, the user should consult the dealer or an experienced radio/television technician for additional suggestions.

DOC NOTICE

The Canadian Department of Communication label identifies certified equipment. This certification means that the equipment meets certain telecommunications network protective, operational and safety requirements. The Department does not guarantee the equipment will operate to the user's satisfaction.

Before installing this equipment, users should ensure that it is permissible to be connected to the facilities of the local telecommunications company. The equipment must also be installed using an acceptable method of connection. In some cases, the company's inside wiring associated with a single line individual service may be extended by means of a certified connector assembly (telephone extension cord). The customer should be aware that compliance with the above conditions may not prevent degradation of service in some situations.

Repairs to certified equipment should be made by an authorized Canadian maintenance facility designated by the supplier. Any repairs or alternations made by the user to this equipment, or equipment malfunctions may give the telecommunications company cause to request the user to disconnect the equipment.

Users should ensure for their own protection that the electrical ground connections of the power utility, telephone lines and internal metallic water pipe system, if present, are connected together. This precaution may be particularly important in rural areas.

CAUTION:

Users should not attempt to make such connections themselves, but should contact the appropriate electric inspection authority, or electrician, as appropriate.

The **Load Number (LN)** assigned to each terminal device denotes the percentage of the total load to be connected to a telephone loop which is used by the device to prevent overloading. The termination on a loop may consist of any combination of devices subject only to the requirement that the total of the Load Number of all the devices does not exceed 100.

- The load number for the CP-90 SSC00017 is equal to 7.

For warranty service, repairs or information contact:
1-800-421-1587

LINEAR LIMITED WARRANTY

This Linear product is warranted against defects in material and workmanship for twelve (12) months. The Warranty Expiration Date is labeled on the product. **This warranty extends only to wholesale customers** who buy direct from Linear or through Linear's normal distribution channels. **Linear does not warrant this product to consumers.** Consumers should inquire from their selling dealer as to the nature of the dealer's warranty, if any. **There are no obligations or liabilities on the part of Linear Corporation for consequential damages arising out of or in connection with use or performance of this product or other indirect damages with respect to loss of property, revenue, or profit, or cost of removal, installation, or reinstallation.** All implied warranties, including implied warranties for merchantability and implied warranties for fitness, are valid only until Warranty Expiration Date as labeled on the product. **This Linear Corporation Warranty is in lieu of all other warranties express or implied.**

For warranty service on Linear equipment return product, at sender's expense to:

Linear Service Center
2580 Pioneer Avenue, Suite C
Vista, CA 92083
Attention: Repairs Department

IMPORTANT !!!

Linear radio controls provide a reliable communications link and fill an important need in portable wireless signalling. However, there are some limitations which must be observed.

- * For U.S. installations only: The radios are required to comply with FCC Rules and Regulations as Part 15 devices. As such, they have limited transmitter power and therefore limited range.
- * A receiver cannot respond to more than one transmitted signal at a time and may be blocked by radio signals that occur on or near their operating frequencies, regardless of code settings.
- * Changes or modifications to the device may void FCC compliance.
- * Infrequently used radio links should be tested regularly to protect against undetected interference or fault.
- * A general knowledge of radio and its vagaries should be gained prior to acting as a wholesale distributor or dealer, and these facts should be communicated to the ultimate users.

Linear

CP-90

**FOR CP-90
VERSION 2.1**

Supervised Wireless Security Control/Communicator



**LISTED
HOUSEHOLD FIRE AND
BURGLARY WARNING
SYSTEM CONTROL UNIT**

*Also suitable as a
Home Health Care
Control Unit and
Grade A Household
Burglar Alarm Unit*

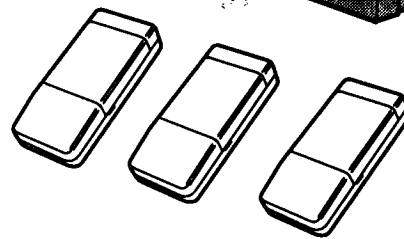
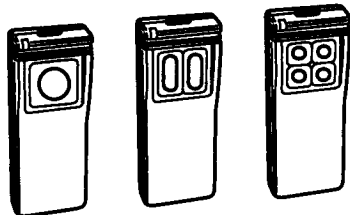
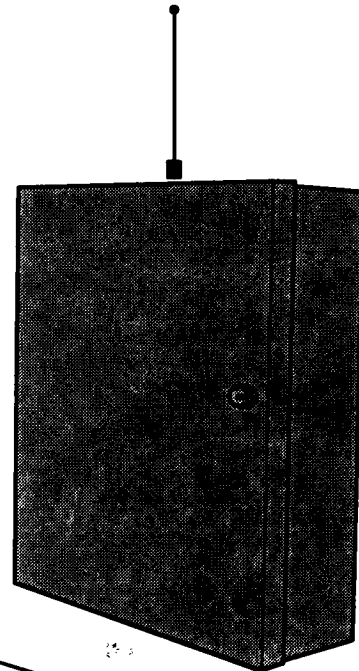
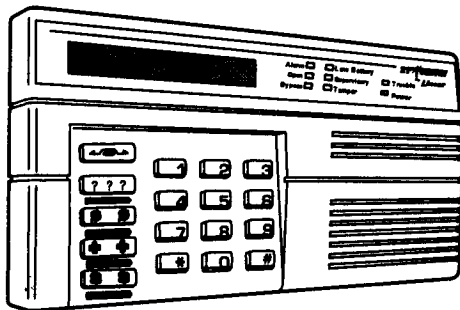

Programming Instructions

Linear

(619) 438-7000 • FAX (619) 438-7043
USA & Canada (800) 421-1587 & (800) 392-0123
Toll Free FAX (800) 468-1340